



UM2100

ATTENUATOR AND POWER PIN DIODES (2-30 MHz)

DESCRIPTION

UM2100 Series PIN diodes are designed for transmit/receive switch and attenuator applications in HF band (2-30MHz) and below. As series configured switches, these long lifetime (25µs typical) diodes can control up to 2.5 kW, CW in a 50 ohm system. In HF band, insertion loss is less than 0.25dB and isolation is greater than 32dB (off-state). The UM2100 series offers the lowest distortion performance in both the transmit and receive modes. Less than 50 mA forward bias is required to obtain an IP3 of

60 dBm at 300 kHz with 1 watt per tone. The forward biased resistance/reactance vs. frequency characteristics are flat down to 10 kHz. The capacitance vs. reverse bias voltage characteristic is flat down to 2 MHz. In attenuator configuration, the UM2100 produces extremely low distortion at low values of attenuator control current, and very low insertion loss (0.2dB) in the "0dB" attenuator state.

KEY FEATURES

- HF band (2-30 MHz) PIN
- Long Lifetime (25µs typical)
- High Power (1kW, CW)
- High Isolation (32dB)
- Low Loss (0.25dB)
- Very Low Distortion (IP3=60dBm)
- Voltage ratings to 1000 V

IMPORTANT: For the most current data, consult MICROSEMI's website: <http://www.microsemi.com>

ABSOLUTE MAXIMUM RATINGS AT 25° C (UNLESS OTHERWISE SPECIFIED)

Package	Condition	PD	θ
A	25 °C Pin Temperature	25 W	6 °C/W
B & E	½ in. total length to 25 °C Contact Free Air	12 W 2.5 W	12.5 °C/W
C	25 °C Stud Temperature	25 W	6 °C/W
D	25 °C Stud Temperature	18.75 W	8 °C/W
SM	25 °C End Cap Temperature	15W	10 °C/W
All	1 us pulse (Single)	100 kW	
OPERATING AND STORAGE TEMPERATURE RANGE		-65 °C to + 175 °C	

APPLICATIONS/BENEFITS

- Isolated stud package available
- Surface mount package available
- RoHS compliant packaging available: use UMX2101B, etc.

VOLTAGE RATINGS

Reverse Voltage @ 10 uA

100V	UM2101
200V	UM2102
400V	UM2104
600V	UM2106
800V	UM2108
1000V	UM2110

ELECTRICAL PARAMETERS @ 25°C (unless otherwise specified)

Parameter	Symbol	Conditions	MIN.	TYPICAL	MAX.	Units
Total Capacitance	CT	$V_R=100V, F=1\text{ MHz}$		1.9	2.5	pF
Series Resistance	R_S	$I_f = 100\text{ mA}, F=2\text{ MHz}$		1.0	2.0	Ohms
Carrier Lifetime	τ	$I_f = 10\text{ mA}/100\text{ V}$	20	25		μs
Reverse Current	I_R	$V_R = \text{Voltage rating}$			10	μA
	IP3	P=2W total, $I_f=25\text{mA}$ F1 = 1.999 MHz F2 = 2.001 MHz 1.0 W/tone	50	60		dBm

Style "B"

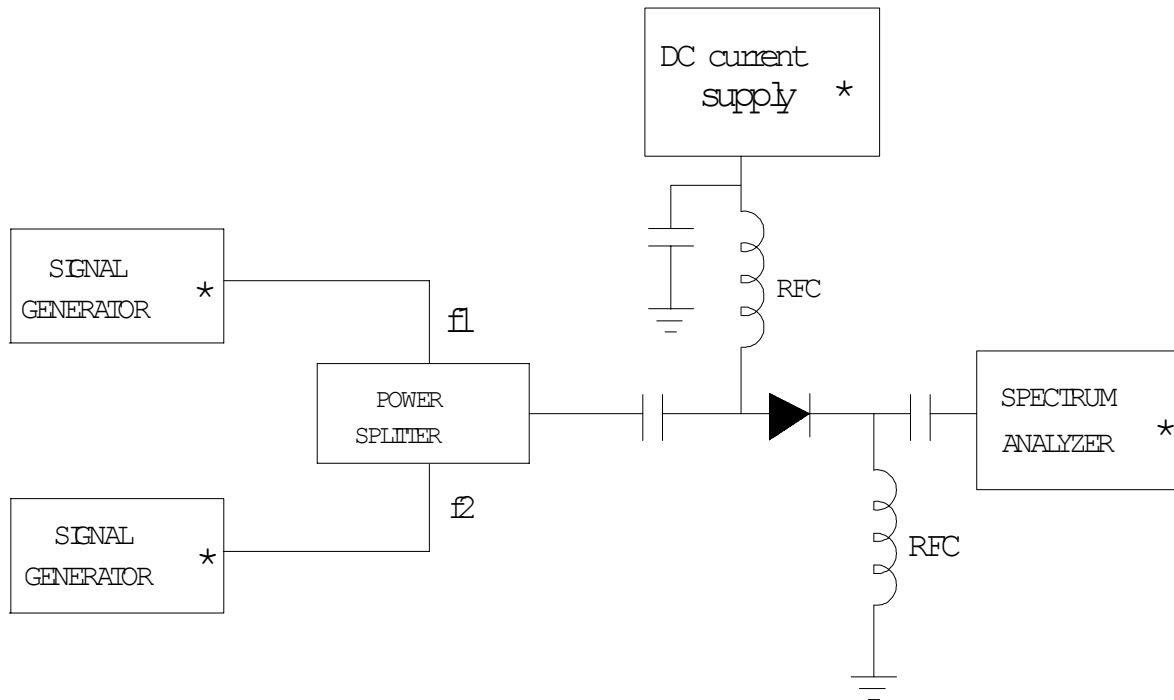
Style "SM"

* May be controlled with the IEEE-488 BUS CIRCUIT

Rs versus If
TYPICAL

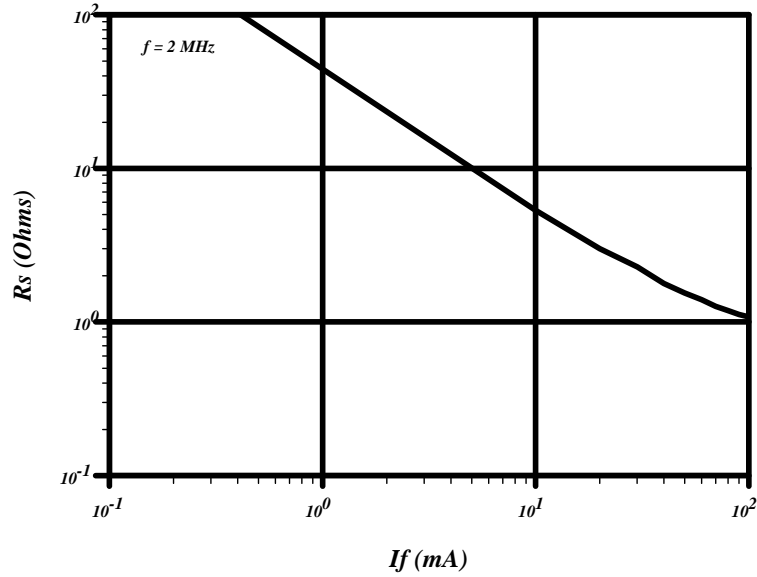

RESISTANCE / REACTANCE VERSUS FREQUENCY
TYPICAL

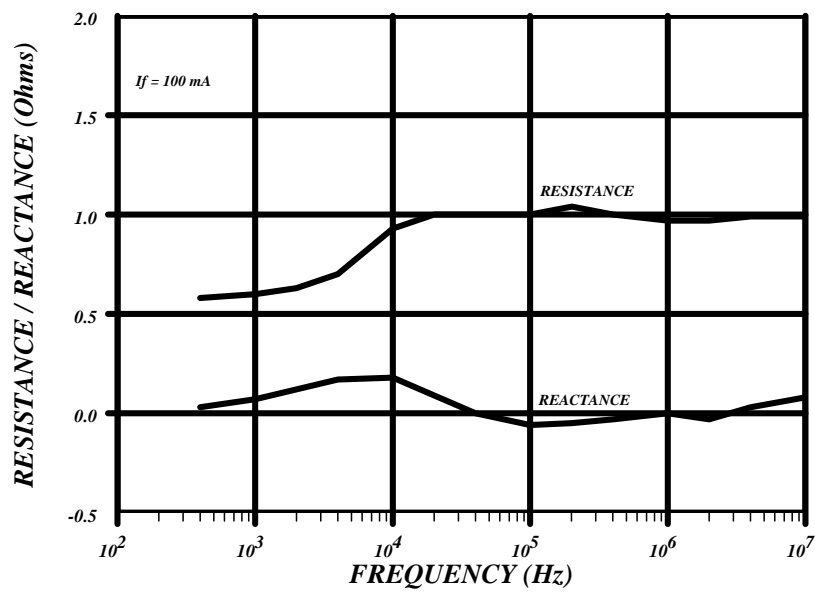

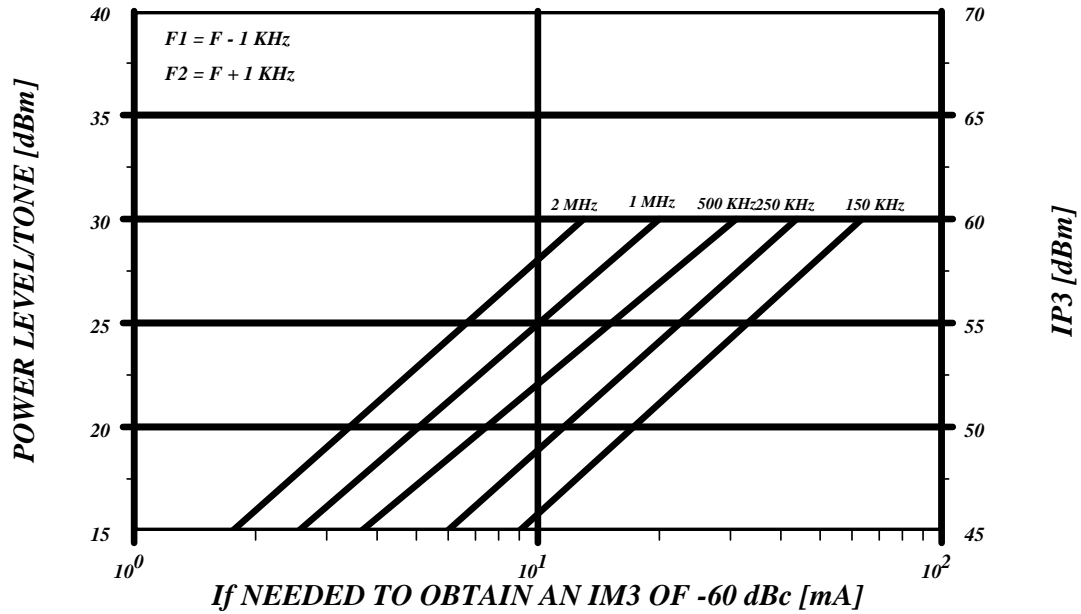
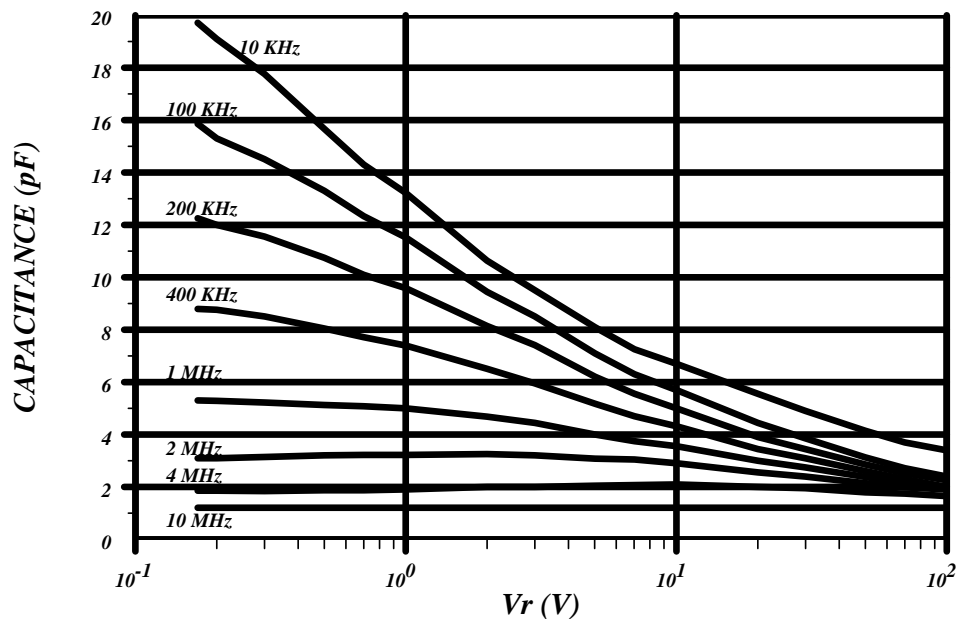
**POWER LEVEL/TONE VERSUS FORWARD BIAS CURRENT
TYPICAL**

**CAPACITANCE VERSUS VOLTAGE
TYPICAL**

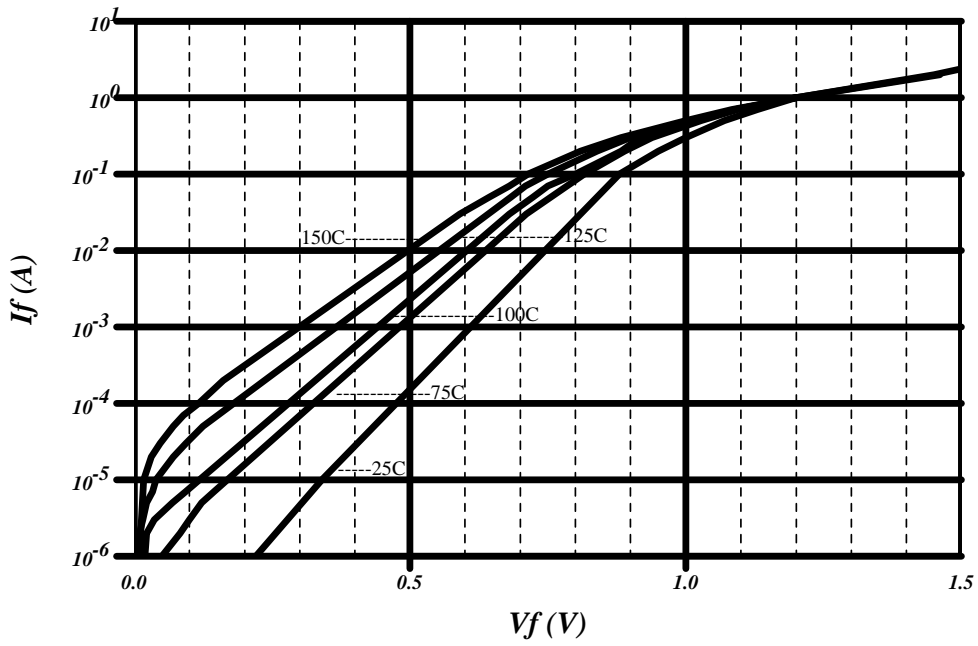
*MEAN I_f VERSUS V_f CURVE VERSUS TEMPERATURE
TYPICAL*

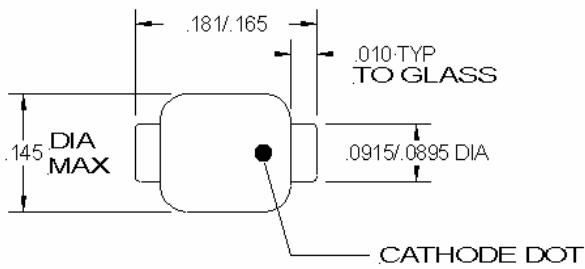
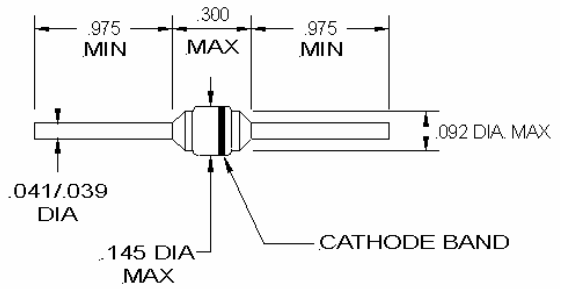
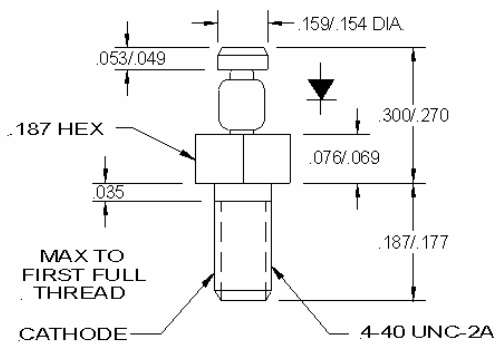
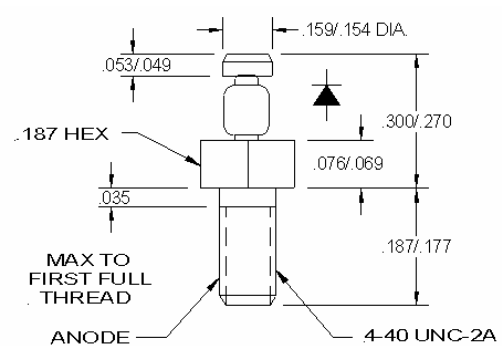

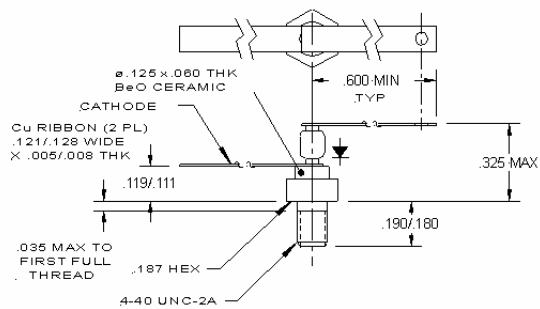
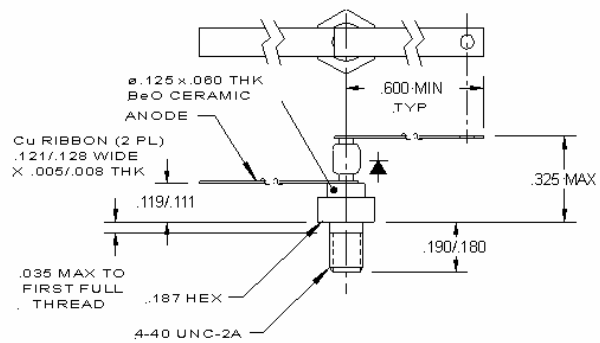
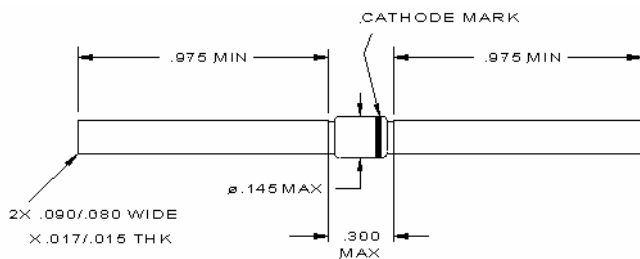
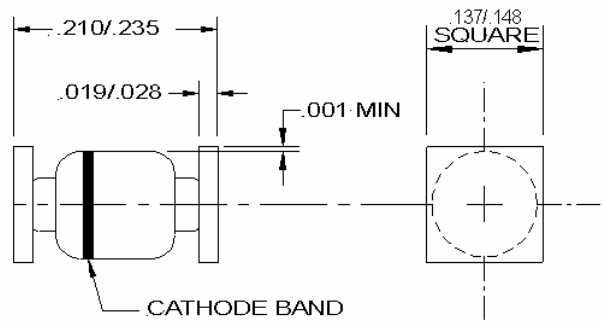
STYLE "A"

STYLE "B"

STYLE "C"

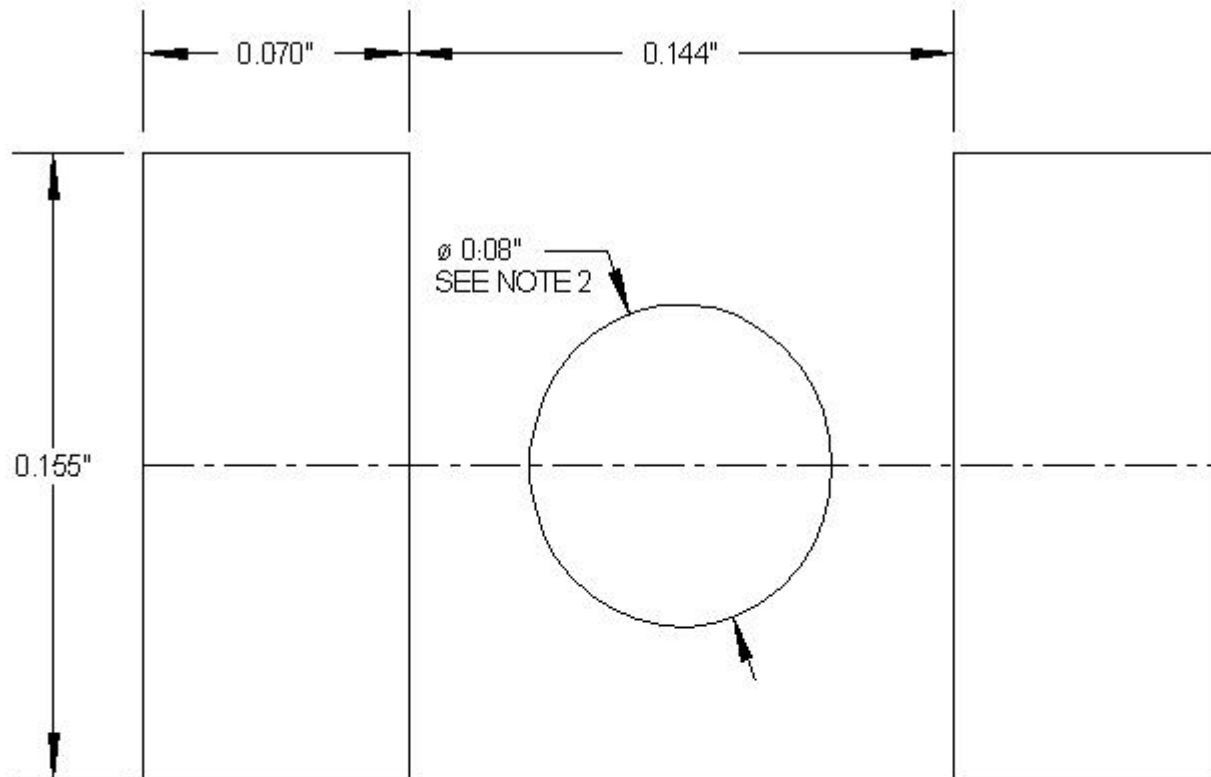
STYLE "CR"

STYLE "D"

STYLE "DR"

STYLE "E"

STYLE "SM"

STYLE "SM" FOOTPRINT



**B SIZE
(STANDARD LARGE
SQUARE END CAP OUTLINE)**

NOTES:

- 1: THESE DIMENSIONS WILL MATCH THE TERMINALS AND PROVIDE FOR ADDITIONAL SOLDER FILLETS AT THE OUTBOARD ENDS AT LEAST AS WIDE AS THE TERMINALS THEMSELVES, ASSUMING ACCURACY OF DEVICE PLACEMENT WITHIN 0.005".
- 2: IF THE MOUNTING METHOD CHOSEN REQUIRES USE OF AN ADHESIVE SEPARATE FROM THE SOLDER COMPOUND, A ROUND (OR SQUARE) SPOT OF CEMENT AS SHOWN SHOULD BE CENTRALLY LOCATED.



UM2100

ATTENUATOR AND POWER PIN DIODES (2-30 MHz)

NOTES: