

DESCRIPTION

The LX1701 family represents a new generation of a fully integrated audio mono class-D amplifier from Microsemi. This CMOS monolithic class-D amplifier series is optimized for low voltage, low power operation and minimum system cost. The products are ideal for use in battery powered applications where low power consumption is desirable such as cell phones, PDA's, web tablets and other low power systems.

The LX1701 family provides very low quiescent current consumption through the use of a proprietary output modulation scheme. This technology enables filter-less operation in many applications. The part features on board, low $R_{ds(on)}$, complementary output MOSFET's that reduces the need for external components.

The LX1701 is offered in a small footprint, low profile surface mountable 16-pin MLPQ package.

IMPORTANT: For the most current data, consult MICROSEMI's website: <http://www.microsemi.com>

KEY FEATURES

- No Output Filter Required
- Low EMI Design
- Low Quiescent Current: 2mA
- Low Shutdown Current: 1µA
- Low And Wide Supply Voltage Range: 1.8-6.0 Volt
- 2W Output Power Into 4Ω Load With THD<1%
- 3W Into 2Ω With THD<1%
- THD+N As Low As 0.09%
- Small Form Factor: 16-pin MLPQ Package: 4mmx4mm
- -40 to +85°C Operating Range
- Only 1 External Component Needed, No Input AC Coupling Capacitor Required, Under Certain Conditions
- Built-in Clock Frequency 200KHz
- Built-in Feedback Loop, Allows High Audio Fidelity
- 14dB/8dB Gain Selectable
- 20/300Hz Bandwidth Selectable
- Shut-down Function
- Internal Thermal Shut-down
- High Efficiency: 85% Through Modulation Scheme And Class-D Operation
- Built-in De-pop Circuit, No Turn ON/OFF "POP" Noise

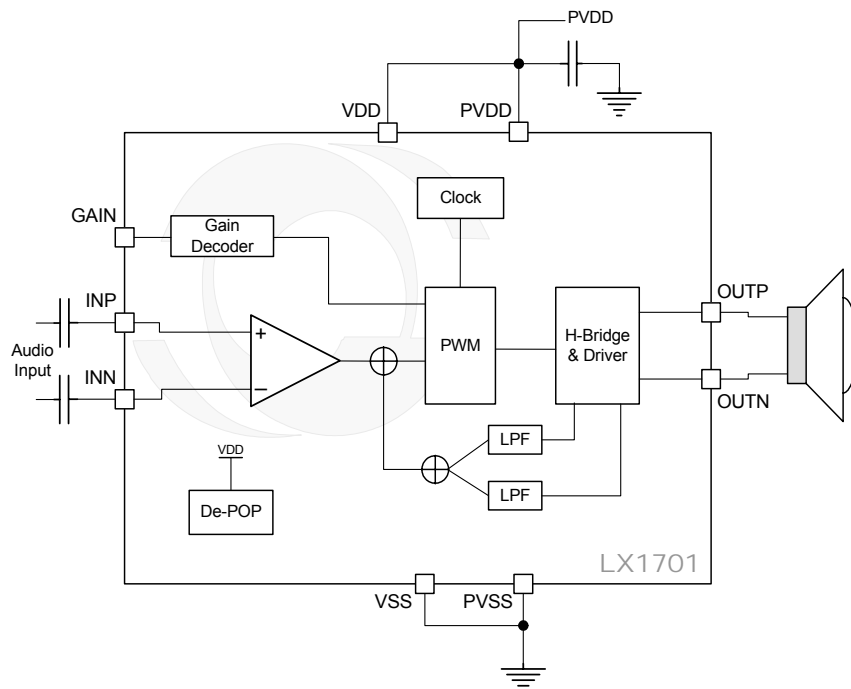
PRODUCT HIGHLIGHT

APPLICATIONS/BENEFITS

- PDA's
- Cell Phones
- Portable Audio
- Laptop Computer Speaker Amplifier
- LCD TV/Desktop Monitor Speaker Amplifier
- PC Audio Multimedia Amplifier

PACKAGE ORDER INFO

T_J (°C)	Bare Die	LQ Plastic MLPQ 16-Pin
	-40 to 85	LX1701

RoHS Compliant / Pb-free

Note: Available in Tape & Reel. Append the letters "TR" to the part number. (i.e. LX1701CLQ-TR)

ABSOLUTE MAXIMUM RATINGS

Positive Supply Voltage (VDD, PVDD)..... -0.3 to 7.0V
 Operating Temperature-40°C to +85°C
 Maximum Operating Junction Temperature 150°C
 Storage Temperature-65°C to 150°C
 Lead Temperature (Soldering, 10 seconds)..... 300°C
 Package Peak Temp for Solder Reflow(40 second maximum exposure)..... 260°C (+0, -5)

Note: Exceeding these ratings could cause damage to the device. All voltages are with respect to Ground. Currents are positive into, negative out of specified terminal.

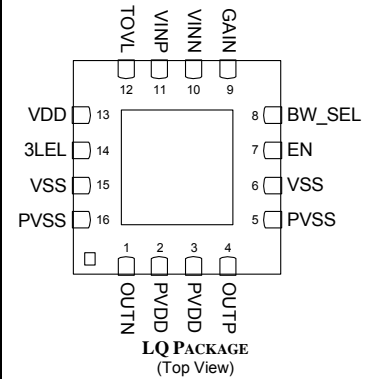
PACKAGE PIN OUT

Pb-free 100% Matte Tin Finish

THERMAL DATA
LQ Plastic Micro Lead Quad Package 16-Pin

THERMAL RESISTANCE-JUNCTION TO CASE, θ_{JC}	3.22°C/W
THERMAL RESISTANCE-JUNCTION TO AMBIENT, θ_{JA}	38.1°C/W

Junction Temperature Calculation: $T_J = T_A + (P_D \times \theta_{JA})$.

The θ_{JA} numbers are guidelines for the thermal performance of the device/pc-board system. All of the above assume no ambient airflow. Thermal Test Board: JESD5-7 (Leaded Surface Mount Package)

FUNCTIONAL PIN DESCRIPTION

Name	Description
OUTN	Negative Audio (PWM) Output
PVDD	Positive Supply to Negative Output Stage
PVDD	Positive Supply to Positive Output Stage
OUTP	Positive Audio (PWM) Output
PVSS	Negative Supply to Positive Output Stage (ground)
VSS	Negative Supply to Analog Stage (ground)
EN	Enable Pin, Active High.
BW_SEL	Bandwidth Selection Pin: VDD 300Hz HP filter VSS No HP (< 20Hz)
GAIN	Gain Selection Pin: Tied to VDD Gain = 14dB Tied to VSS Gain = 8dB
VINN	Negative Audio Input
VINP	Positive Audio Input
TOVL	Thermal Overload Indicator Output, Active HIGH.
VDD	Analog Positive Power Supply
3LVL	Three Level Modulation Selection Pin: Tied to VSS 2 LEVEL PWM Modulation Scheme, +PVDD -PVDD; Tied to VDD 3 LEVEL PWM Modulation Scheme, +PVDD PVSS -PVDD;
VSS	Negative Power Supply to Analog Stage
PVSS	Negative Supply to Negative Output Stage (ground)

SYSTEM CHARACTERISTICS

Unless otherwise specified, the following specifications apply over the operating ambient temperature $T_A = 25^\circ\text{C}$ except where otherwise noted and the following test conditions: Default settings: 20Hz corner low frequency, 14dB gain.

Parameter	Symbol	Test Conditions	LX1701			Units
			Min	Typ	Max	
Supply Current, Quiescent	IQQ	No Load, VDD = PVDD = 1.8V		0.9	1.2	mA
		No Load, VDD = PVDD = 3.3V		1.3	1.8	
		No Load, VDD = PVDD = 5.0V		2.0	2.5	
Supply Current, Shutdown Mode	IQQSD	Disable pin active			1	μA
Output Power @ 8 Ohms	PO	VDD = PVDD = 5V, Fin = 1kHz	THD+N = 1%	1.3		W
			THD+N = 10%	1.8		
		VDD = PVDD = 3.3V, Fin = 1kHz	THD+N = 1%	0.5		
			THD+N = 10%	0.7		
Output Power @ 4 Ohms	PO	VDD = PVDD = 5V, Fin = 1kHz	THD+N = 1%	2.1		W
			THD+N = 10%	2.8		
		VDD = PVDD = 3.3V, Fin = 1kHz	THD+N = 1%	0.9		
			THD+N = 10%	1.2		
Output Power @ 2 Ohms	PO	VDD = PVDD = 5V, Fin = 1kHz	THD+N = 1%	3.0		W
			THD+N = 10%	3.9		
		VDD = PVDD = 3.3V, Fin = 1kHz	THD+N = 1%	1.3		
			THD+N = 10%	1.8		
Power Efficiency	η	VDD = PVDD = 5V, Fin = 1kHz, RL = 8 Ω		85		%
Total Harmonic Distortion @ 50% of Max Power	THD+N	VDD = PVDD = 5V, Fin = 1kHz, RL = 8 Ω		0.09		%
Signal-to-Noise Ratio	SNR	VDD = PVDD = 5V, F = 1KHz, PO = 1W, A-Weighted		99		dB
Output Noise Floor	VN	Input Grounded A-weighted 20-20kHz		25		μV_{RMS}
Frequency Response Lower Corner Frequency	FLO	3dB relative to 1kHz, BW Select = VSS		20		Hz
	FHI	3dB relative to 1kHz, BW Select = VDD		300		Hz
Frequency Response		VDD = PVDD = 1.8 to 5.5V, RL = 4 Ω , PO = 200mW @ 20~80KHz, filterless			3	dB
Power Supply Rejection Ratio	PSRR	VDD = PVDD = 1.8V to 5.5V		65		dB
Common Mode Rejection Ratio	CMRR	VDD = PVDD = 1.8V to 5.5V		70		dB
Gain	GSYS	Pin 9 tied to VDD, VDD = PVDD = 1.8V to 5.5V		14		dB
		Pin 9 tied to VSS, VDD = PVDD = 1.8V to 5.5V		8		

ELECTRICAL CHARACTERISTICS

Unless otherwise specified, the following specifications apply over the operating ambient temperature $-40^{\circ}\text{C} \leq T_A \leq 85^{\circ}\text{C}$ except where otherwise noted.

Parameter	Symbol	Test Conditions	LX1701			Units
			Min	Typ	Max	
Supply Voltage	VDD PVDD		1.8		6.0	V
Oscillator Frequency	fSW	VDD = PVDD = 1.8~5.5V	180	200	225	KHz
Supply Current, Quiescent	IQQ	No Load	VDD = PVDD = 5V	2.0	2.5	mA
			VDD = PVDD = 3.3V	1.3	1.8	
			VDD = PVDD = 1.8V	0.9	1.2	
Supply Current, Shutdown Mode	IQQSD	Disable Pin active			1	μA
Power Supply Rejection Ratio	PSRR	VDD = PVDD = 1.8V to 5.5V		65		dB
Common Mode Rejection Ratio	CMRR	VDD = PVDD = 1.8V to 5.5V		70		dB
Input Impedance						
Input voltage Range	VIN	VDD = PVDD = 1.8~5.5V	-0.3		VDD +0.3	V
Input Resistance Differential	K _{IN}	Gain = 14dB, BW = 20Hz		65		K Ω
		Gain = 14dB, BW = 300Hz		72		
		Gain = 8dB, BW = 20Hz		98		
		Gain = 8dB, BW = 300Hz		102		
Output DC Offset	VOFF	Input shorted to GND, 20Hz corner, 14dB gain VDD = PVDD = 3.3V		2	8	mV
Input DC Offset Dynamic Range Max. with Output VOFF < 200mV	V _{INOFF}	Gain = 14dB BW = 20Hz, PVDD = 5V		0.14		V
		Gain = 14dB, BW = 300Hz, PVDD = 5V		1.50		
		Gain = 8dB, BW = 20Hz, PVDD = 5V		0.25		
		Gain = 8dB, BW = 300Hz, PVDD = 5V		2.70		
Static Drain-to-source ON-Resistance	R _{DS(ON)}	VDD = PVDD=5V	P Channel	360		m Ω
			N Channel	350		
		VDD = PVDD=3.3V	P Channel	490		
			N Channel	460		
		VDD = PVDD=1.8V	P Channel	600 [†]		
			N Channel	600 [†]		
Stage Gain	GH GL	Pin 9 tied to VDD, VDD = PVDD = 1.8V to 5.5V		14		dB
		Pin 9 tied to VSS, VDD = PVDD = 1.8V to 5.5V		8		
Thermal Indicator Junction	T _J			150		$^{\circ}\text{C}$
Thermal Indicator Output	VTOVL	VDD = PVDD = 1.8~5.5V		VDD	VDD +0.3	V
Under Voltage Threshold Level	VUV		1.55	1.65	1.75	V
Enable Threshold		VDD = PVDD = 3.3V	1.3	1.5	1.7	V

[†] At +85 $^{\circ}\text{C}$ ambient temperature.

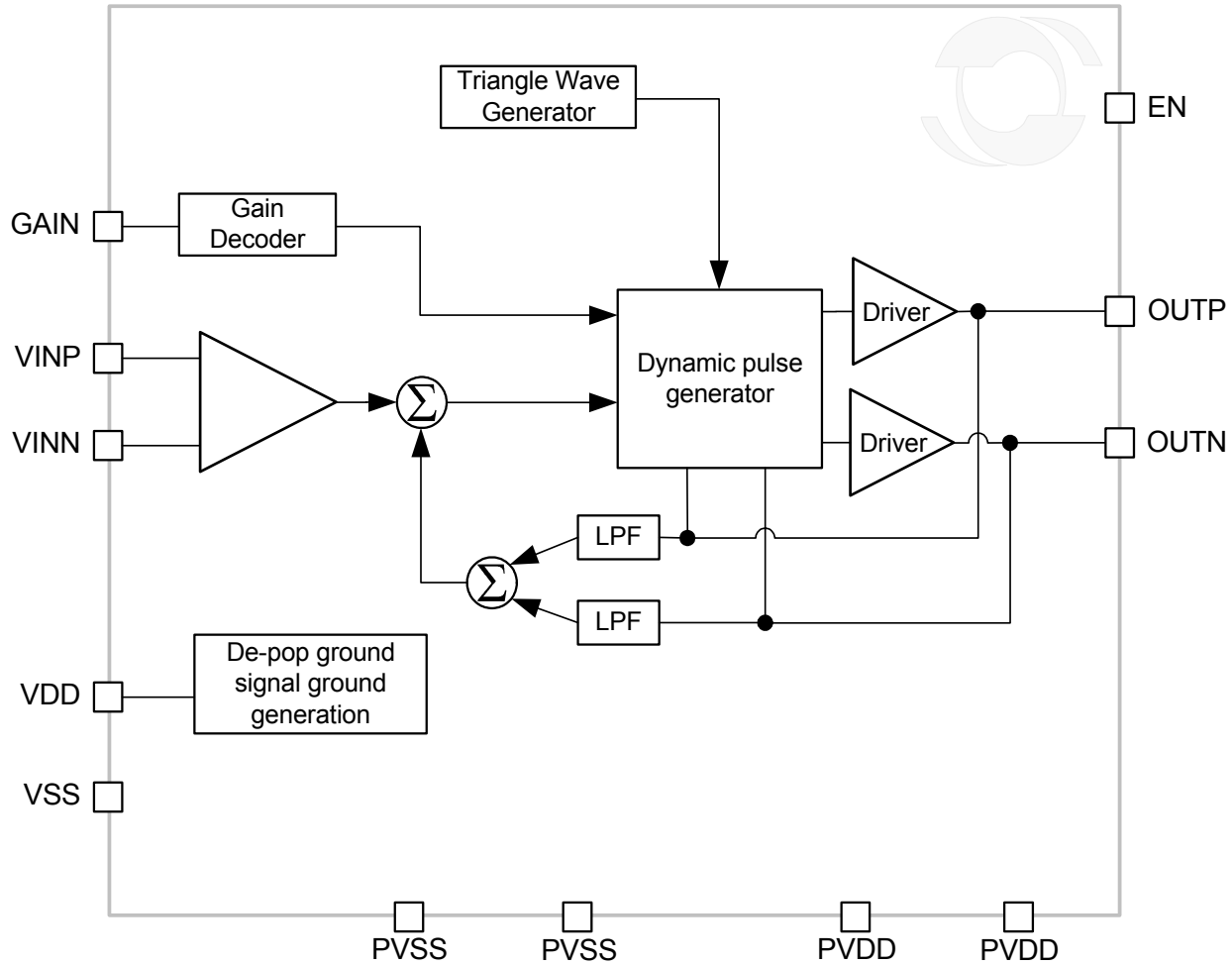
SIMPLIFIED BLOCK DIAGRAM

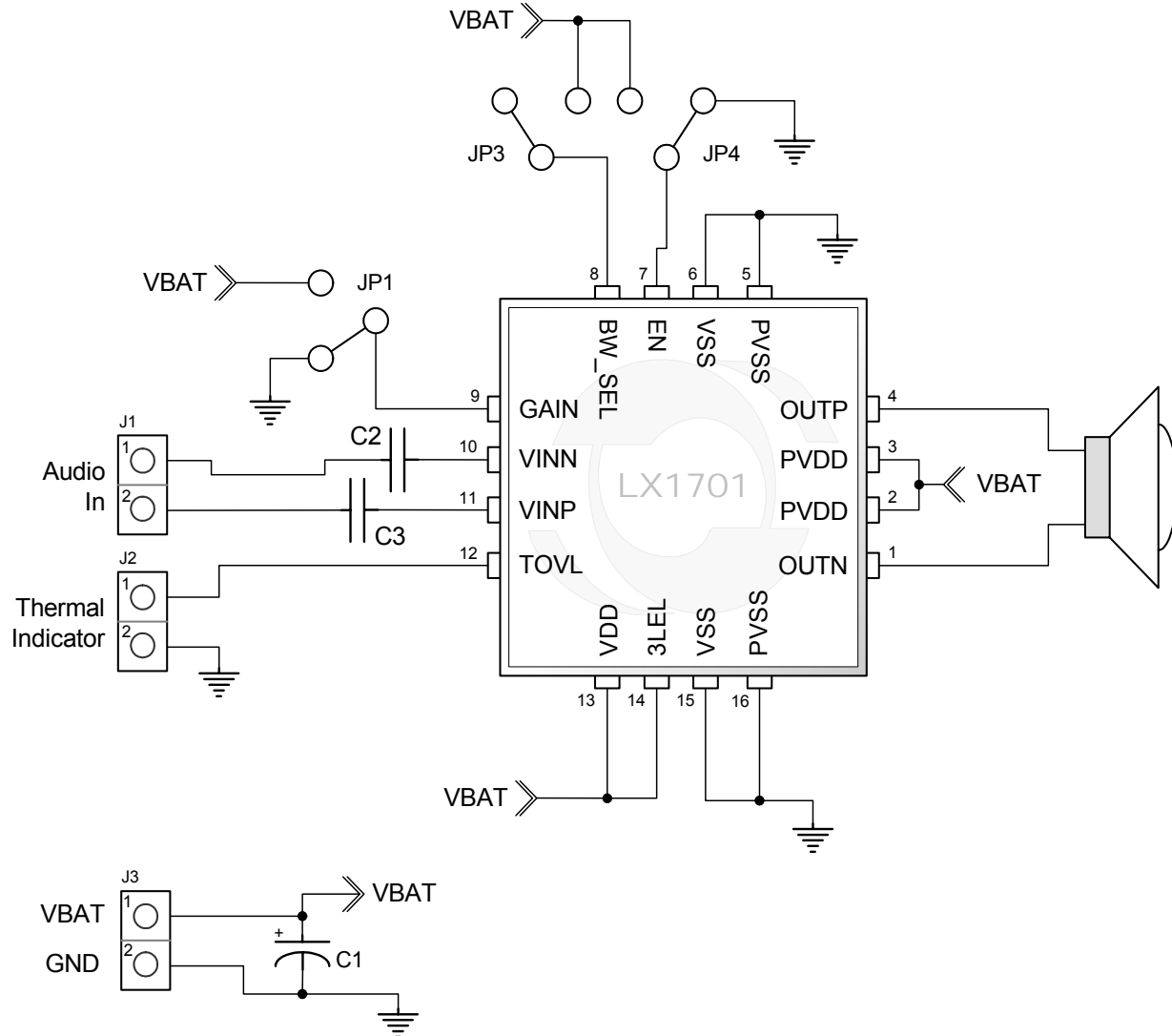
Figure 1 – LX1701 Simplified Block Diagram

TYPICAL APPLICATION SCHEMATIC

Figure 2 – LX1701 Typical Application Circuit

FUNCTIONAL DESCRIPTION**GENERAL DESCRIPTION**

The LX1701 is a filterless, low-EMI, class-D audio power amplifier. It offers high performance (THD+N is just 0.1% at 2W), high efficiency (>85% at 1.2W), and best in class EMI radiation (just 20dBuV/m). The internal signal path is completely differential to minimize common-mode noise pickup. The inputs may be driven single-ended or differentially and they may be direct or AC coupled. The LX1701 may be operated with just a single decoupling capacitor.

FILTERLESS 3-LEVEL CLASS-D MODULATION

The LX1701 output stage is configured as a full H-bridge push-pull driver. The speaker must be driven differentially from the OUPP and OUTN pins. Each side of the speaker is driven by a 200KHz switching signal that transitions between Vdd and GND. With zero input voltage, the duty cycle at each output is around 50% and the signals are in-phase with each other. In this case, there is basically no differential voltage across the speaker. When the input signal goes positive, the duty cycle at OUPP increases above 50% and the duty cycle at OUTN decreases below 50%. This causes a net positive current to flow into the speaker. A negative input voltage causes the OUTN duty cycle to increase and the OUPP duty cycle to decrease which causes a net negative current to flow into the speaker. The differential voltage across the speaker has a fundamental frequency of twice the 200KHz switching frequency. The speaker itself serves as the low pass filter which then recreates the audio signal. This type of modulation can be described as driving +Vdd, -Vdd, and 0V across the speaker which is why it is referred to as 3-Level modulation.

Classical, 2-Level modulation drives either +Vdd or -Vdd across the speaker at all times. This scheme requires an L-C filter between the amplifier's outputs and the speaker in order to keep the output current low.

LOW-EMI OUTPUT STAGE WITH SLEW RATE LIMITING AND ACTIVE OVERSHOOT CLAMPING

With 3-Level modulation, the carrier frequency drives a full amplitude common-mode signal to the speaker wires. This can cause high EMI radiation. One way to combat this would be to filter the outputs with L-C filters or ferrite beads located close to the amplifier. In the LX1701, the output stage has been carefully designed to minimize EMI radiation so that these types of filters are not required. Slew rate limiting is used to keep the outputs from switching too quickly. Active overshoot clamping is used to minimize the inductive overshoot which occurs at each transition. These two techniques allow the LX1701 to easily meet FCC standards for radiated emissions when driving up to 3 meters of speaker wire.

ACTIVE DC INPUT OFFSET CANCELLATION

An internal DC servo loop senses the output differential voltage and feeds it back to the error amplifier through a low pass filter. The corner frequency of this filter can be set at 20Hz or 300Hz via a control pin. This allows the LX1701 to reject signals below these frequencies. Since this is an active control loop, it does not have the same dynamic range as a purely passive solution (such as an input AC-coupling capacitor). The dynamic range of the offset cancellation loop is a function of the selected gain and high pass corner frequency. In applications where the input offset may be higher than the DC offset cancellation range, AC-coupling capacitors should be used.

DIFFERENTIAL SIGNAL PATH, WIDE DYNAMIC RANGE, AND BUILT-IN THERMAL OVERLOAD PROTECTION

The fully differential signal path uses delta-sigma techniques and multiple feedback loops to provide high performance and low distortion. This is all fully-integrated to eliminate the need for any external feedback components or filters. The gain can be selected to be either 8 or 14dB by a control pin. The differential signal path and internal voltage boosters allow for wide dynamic range. In fact, the LX1701 can be operated from supplies as low as 1.8V and as high as 6V. The output power will be limited by the available supply voltage. An internal thermal sensing circuit shuts down the outputs and forces the TOVL output pin high when the junction temperature exceeds about 150degC to provide thermal overload protection.

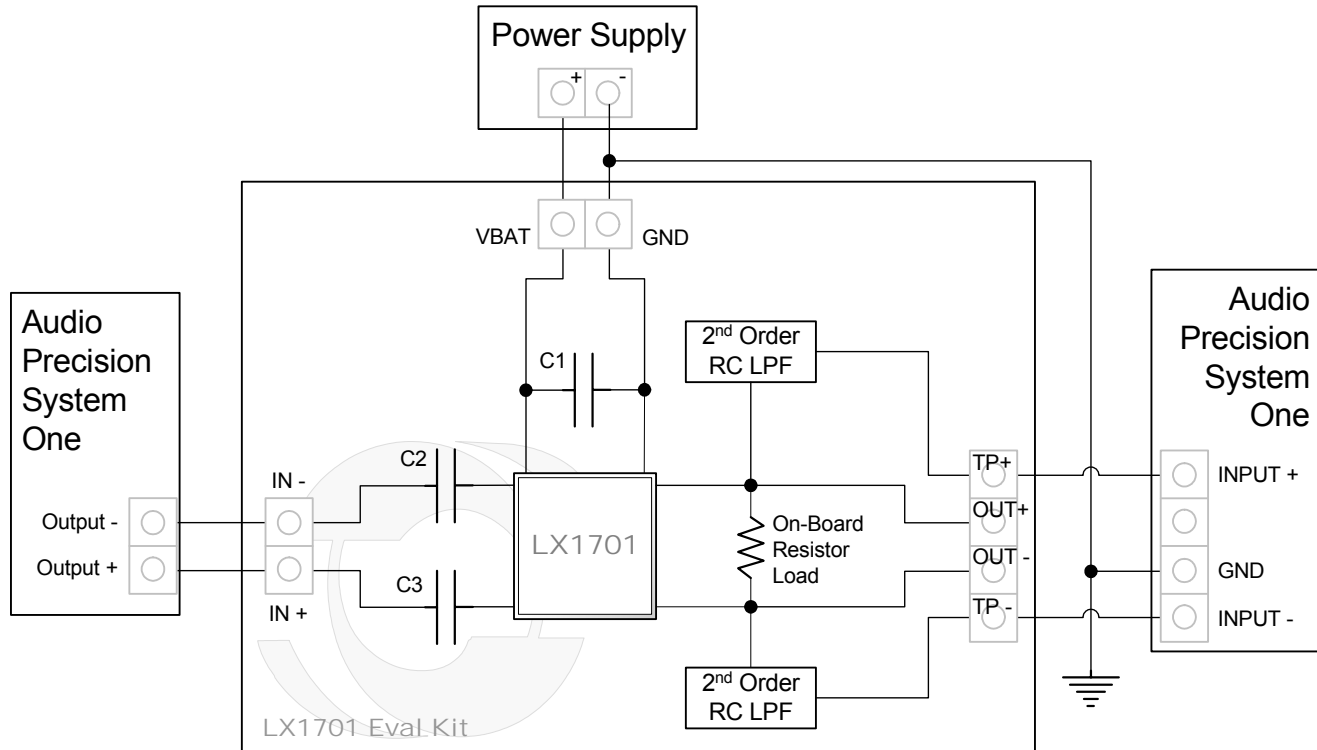
EVALUATION MODULE TEST SET-UP

Figure 3 – Typical Test Setup Circuit
Default Settings:

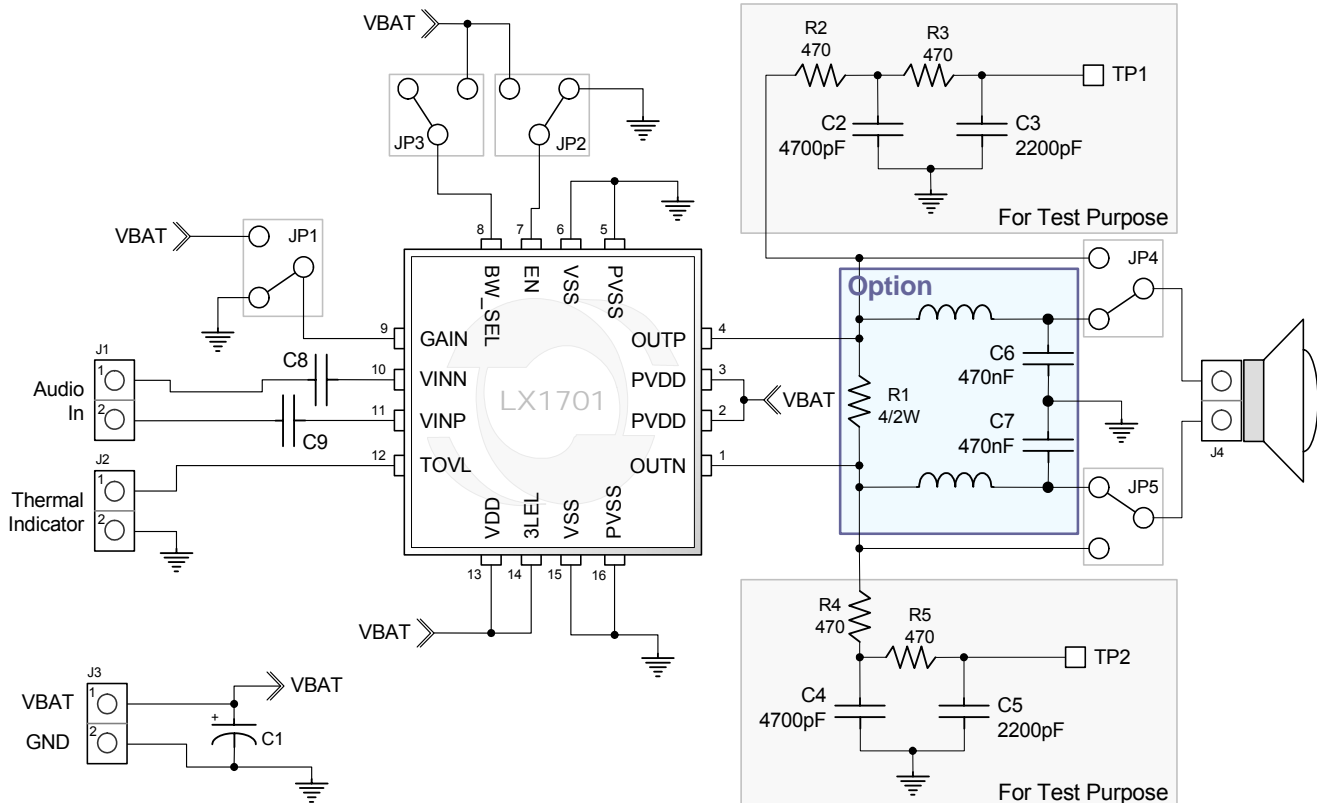
Equipments: Audio Precision SYSTEM 1,
Oscilloscope,
Power Supply ~+5V;
Supply Voltage: 1.8V/3.3V/5.0V 3 corner voltages
On-Board passive LPF: 40KHz cut off frequency (-3dB)
On-Board resistor load: 2/4/8 Ω , 5W
AP settings: 10Hz ~ 22KHz BPF

APPLICATION INFORMATION

*C1 Value is dependant on the current drain from power supply, 1.0 ~ 33 μ F with output power 350mW ~ 3.5W

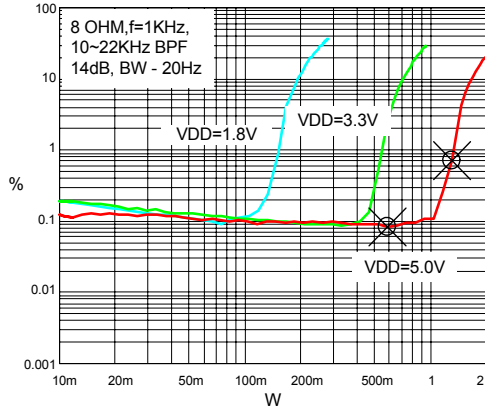
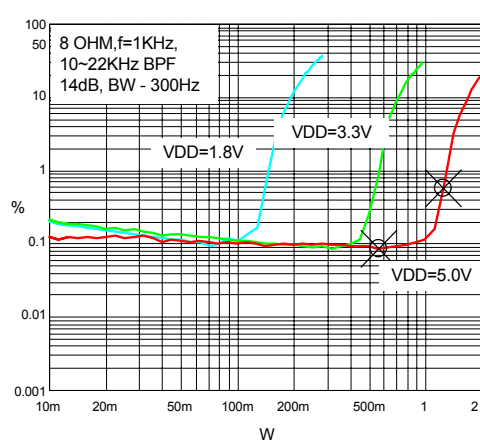
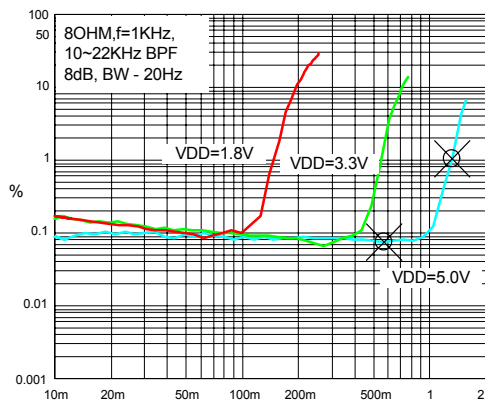
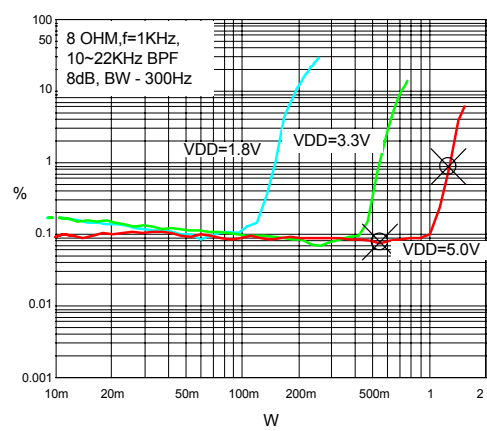
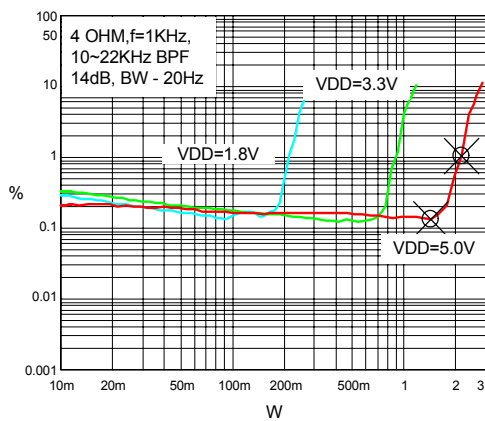
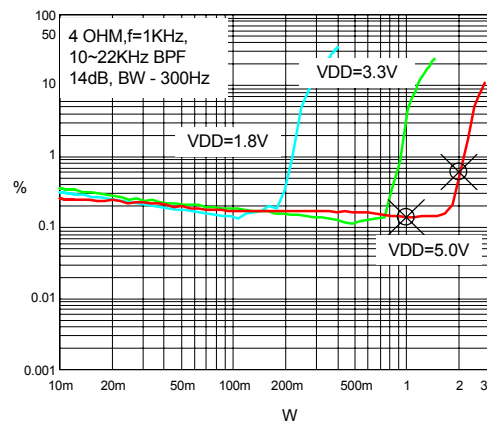
Figure 4 – LX1701 Evaluation Module Schematic

THD+N vs. Power

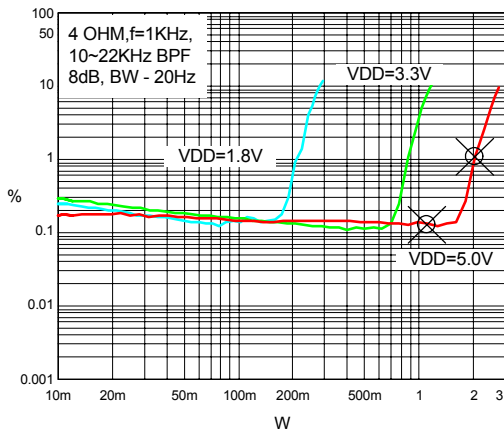
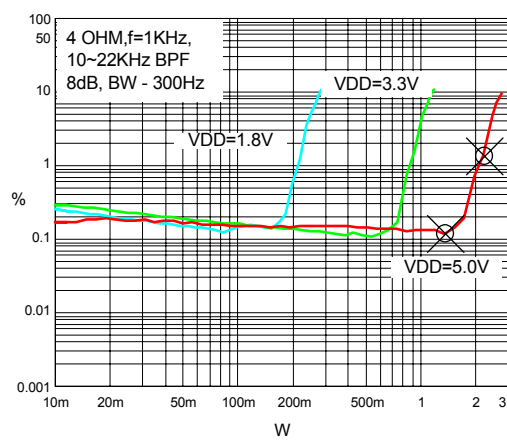
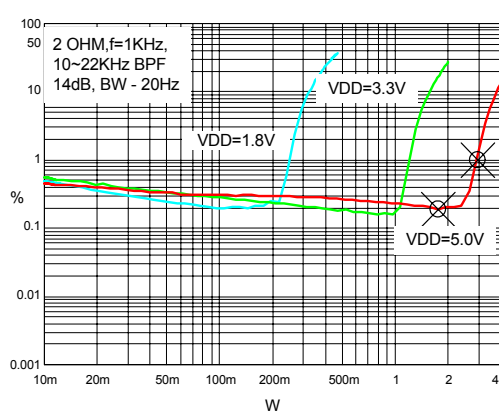
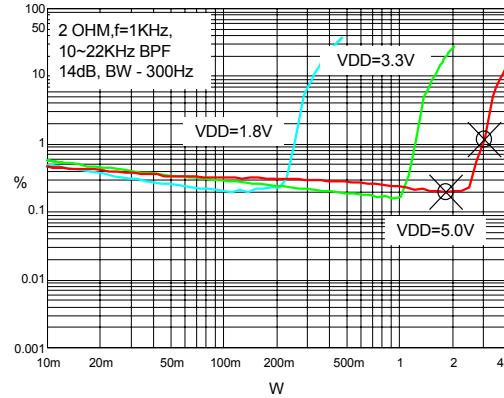
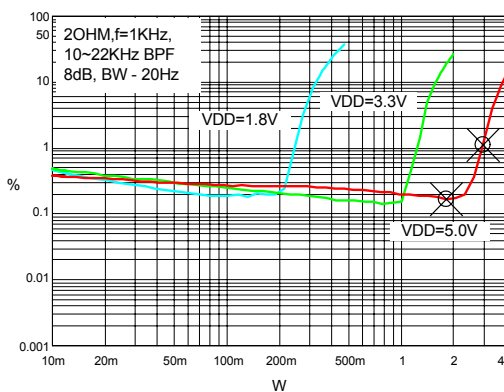
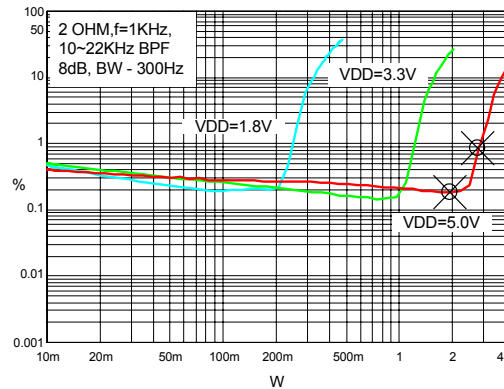
THD+N vs. Power

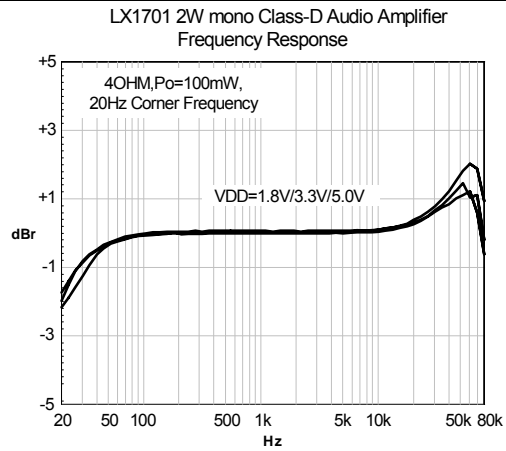
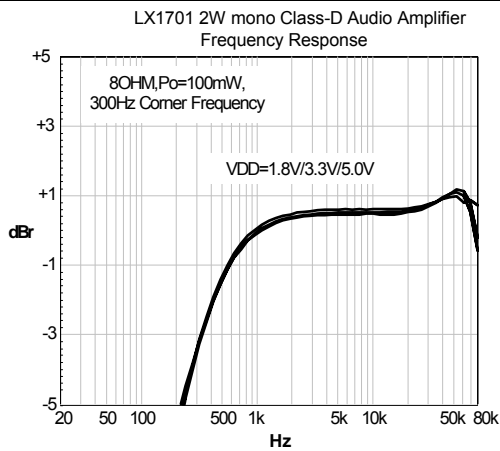
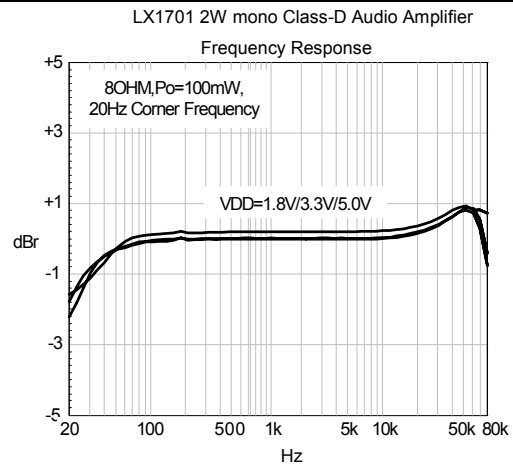
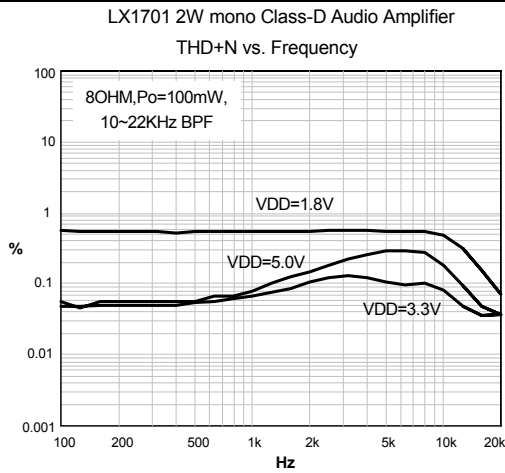
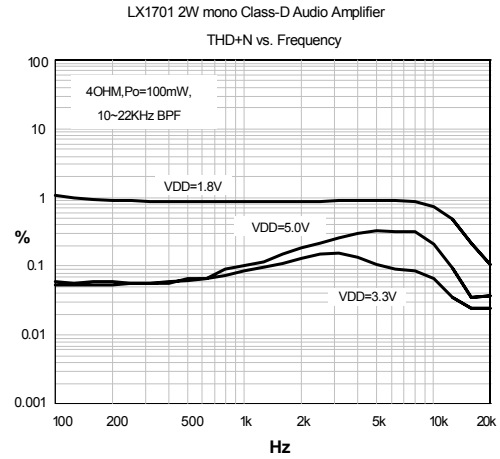
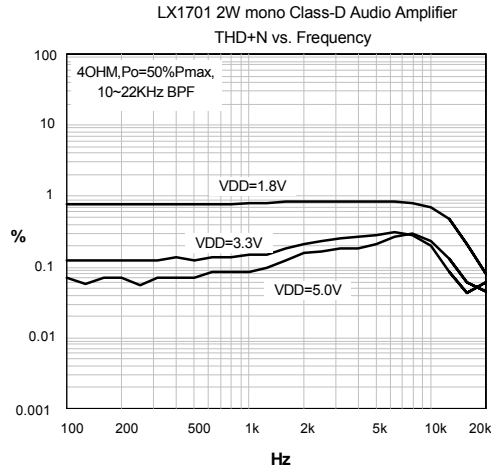
THD+N vs. Power

THD+N vs. Power

THD+N vs. Power

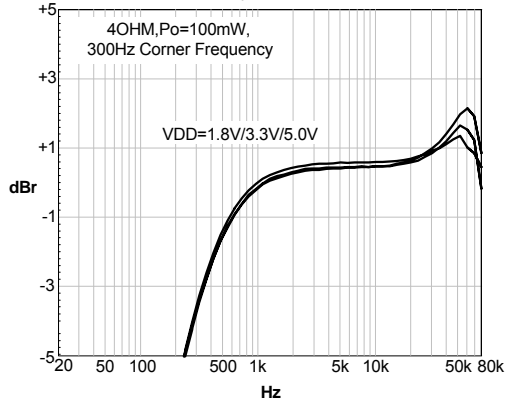
THD+N vs. Power

THD+N vs. Power

THD+N vs. Power

THD+N vs. Power

THD+N vs. Power

THD+N vs. Power

THD+N vs. Power





LX1701 2W mono Class-D Audio Amplifier
Frequency Response



LX1701 2W mono Class-D Audio Amplifier
System Gain

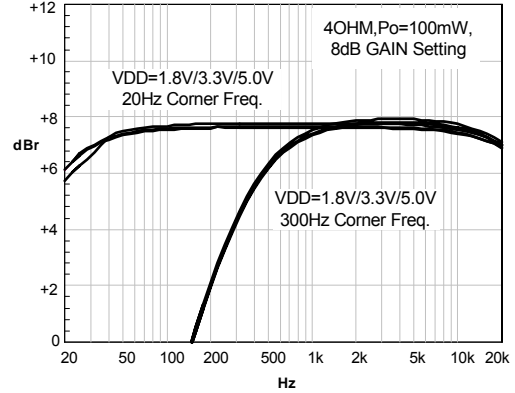

LX1701 2W mono Class-D Audio Amplifier
System Gain

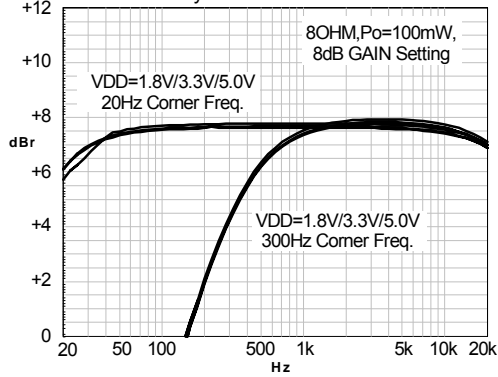

LX1701 2W mono Class-D Audio Amplifier
System Gain

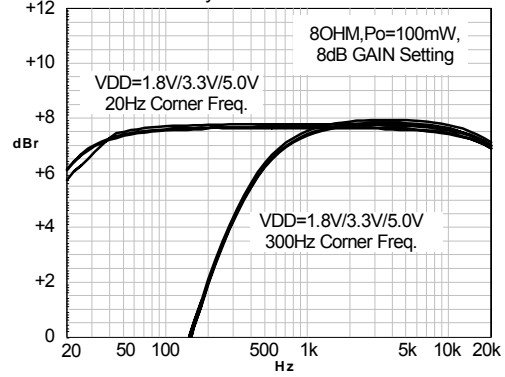

LX1701 2W mono Class-D Audio Amplifier
System Gain

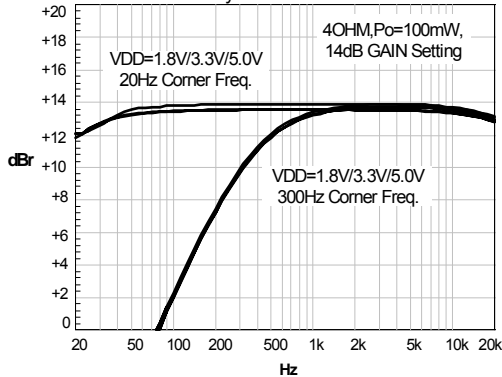

LX1701 2W mono Class-D Audio Amplifier
System Gain

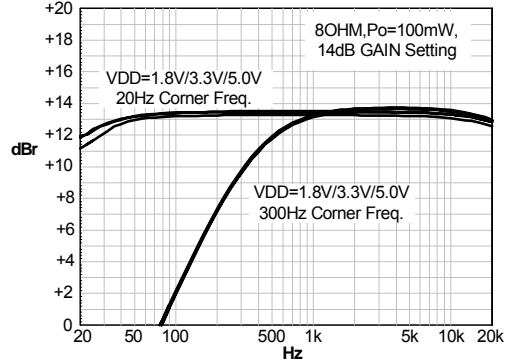

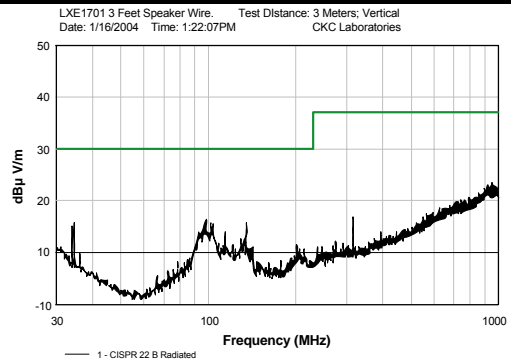
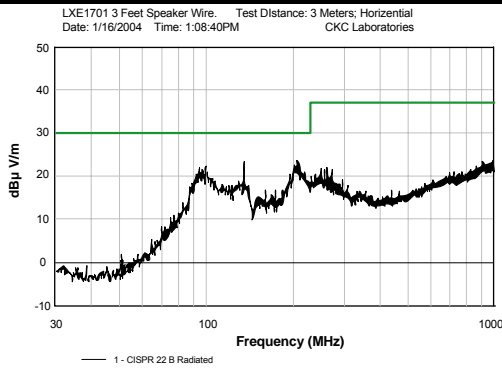
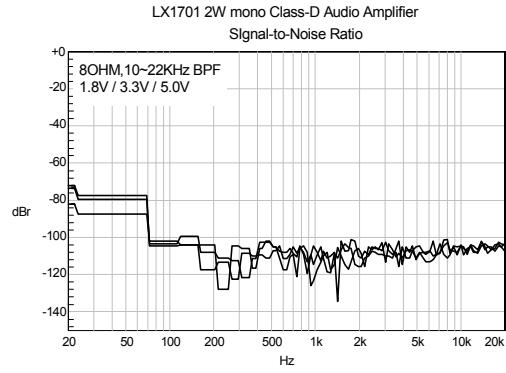
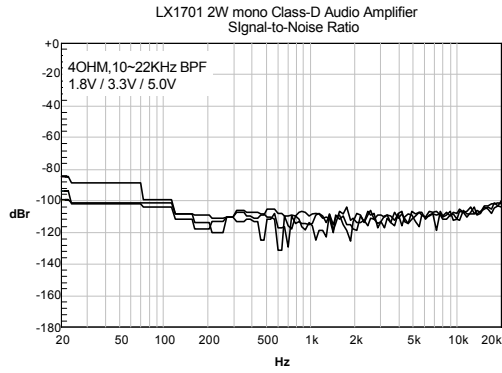

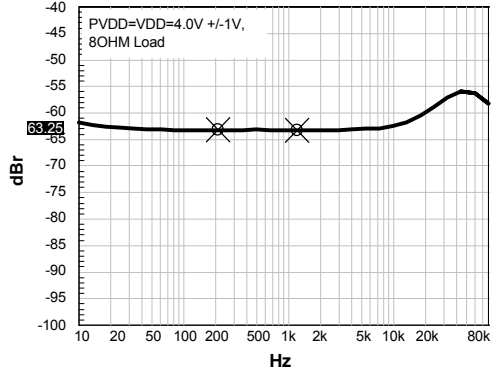
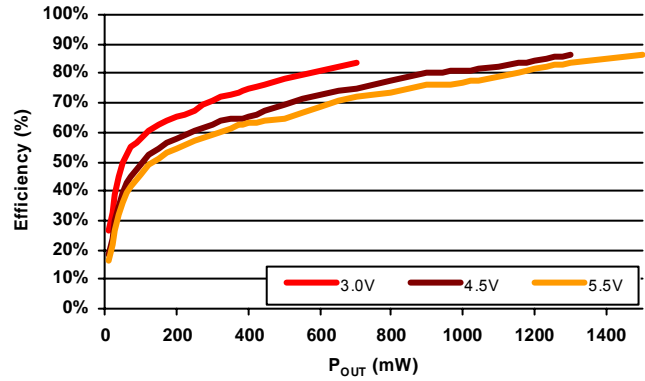
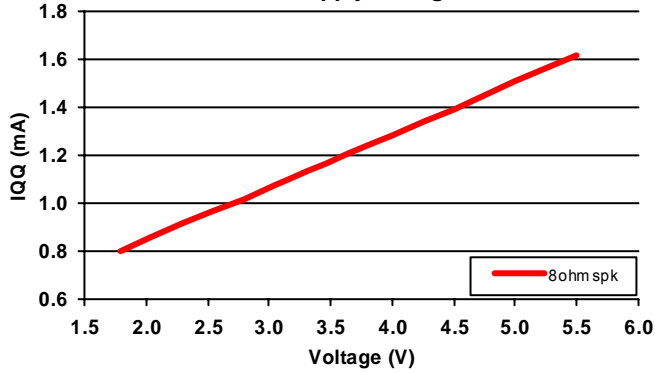
LX1701 Power Supply Rejection Ratio

Power Efficiency (8 Ohm)

IQQ Vs. Supply Voltage

PCB DESIGN GUIDELINES
PCB DESIGN GUIDELINES

One of the key efforts in implementing the MLP package on a pc board is the design of the land pattern. The MLP has rectangular metallized terminals exposed on the bottom surface of the package body. Electrical and mechanical connection between the component and the pc board is made by screen printing solder paste on the pc board and reflowing the paste after placement. To guarantee reliable solder joints it is essential to design the land pattern to the MLP terminal pattern, exposed PAD and Thermal PAD via. There are two basic designs for PCB land pads for the MLP: Copper Defined style (also known as Non Solder Mask Defined (NSMD)) and the Solder Mask Defined style (SMD). The industry has had some debate of the merits of both styles of land pads, and although we recommend the Copper Defined style land pad (NSMD), both styles are acceptable for use with the MLP package. NSMD pads are recommended over SMD pads due to the tighter tolerance on copper etching than solder masking. NSMD by definition also provides a larger copper pad area and allows the solder to anchor to the edges of the copper pads thus providing improved solder joint reliability.

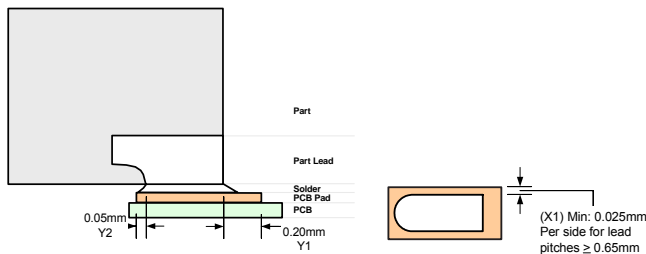
DESIGN OF PCB LAND PATTERN FOR PACKAGE TERMINALS

As a general rule, the PCB lead finger pad (Y) should be designed 0.2-0.5mm longer than the package terminal length for good filleting. The pad length should be extended 0.05mm towards the centerline of the package. The pad width (X) should be a minimum 0.05mm wider than the package terminal width (0.025mm per side), refer to figure 5. However, the pad width is reduced to the width of the component terminal for lead pitches below 0.65mm. This is done to minimize the risk of solder bridging.

Figure 5 – PC Board Land Pattern Geometry for MLP Terminals
EXPOSED PAD PCB DESIGN

The construction of the Exposed Pad MLP enables enhanced thermal and electrical characteristics. In order to take full advantage of this feature the exposed pad must be physically connected to the PCB substrate with solder.

The thermal pad (D2th) should be greater than D2 of the MLP whenever possible, however adequate clearance (Cpl > 0.15mm) must be met to prevent solder bridging. If this clearance cannot be met, then D2th should be reduced in area. The formula would be: $D2TH > D2$ only if $D2TH < Gmin - (2 \times Cpl)$.

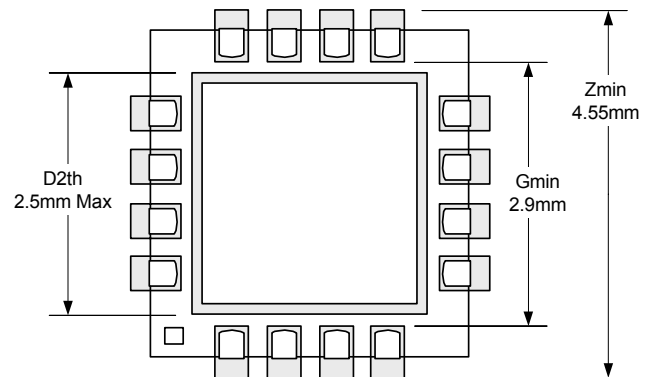
Figure 6 – Land Pattern for LQ16 (4x4mm)

$$Zmin = D + aaa + 2(0.2)$$

(where pkg body tolerance $aaa = 0.15$)
 (where 0.2 is outer pad extension)

$$Gmin = D - 2(Lmax) - 2(0.05)$$

(where 0.05 is inner pad extension)
 ($Lmax = 0.50$ for this example)

$$D2th \text{ max} = Gmin - 2(CpL)$$

(where $CpL = 0.2$)

PCB DESIGN GUIDELINES (CONTINUED)
THERMAL PAD VIA DESIGN

There are two types of on-board thermal PAD design, one is using thermal vias to sink the heat to the other layer with metal traces. Based on Jedec Specification JESD 51-5, the thermal vias should be designed like Figure 7. Another one is the no via thermal PAD which is using the same side copper PAD as heatsink, this type of thermal PAD is good for two layer board, since the bottom side is filled with all other kinds of trace also, it's hard to use the whole plane for the heatsink. But you still can use vias to sink the heat to the bottom layer by the metal traces, then layout a NMSD on which a metal heatsink is put to sink the heat to the air.

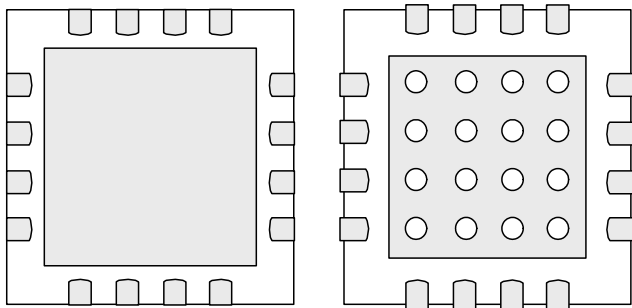

Micro Lead Quad
Package Land Pattern

Land Pattern for Four
Layer Board with Vias

Figure 7 – Comparison of land pattern theory

For LX1701 with MLPQ-4x4 16Lds p ackage, which has $\theta_{jA} = 38.1^{\circ}\text{C}/\text{W}$ by package itself, with maximum 2W (@4ohm) output it only has 300mW power dissipation (assuming 85% efficiency), which only has 11.4°C temperature rise. So the non-via type thermal PAD is suggested.

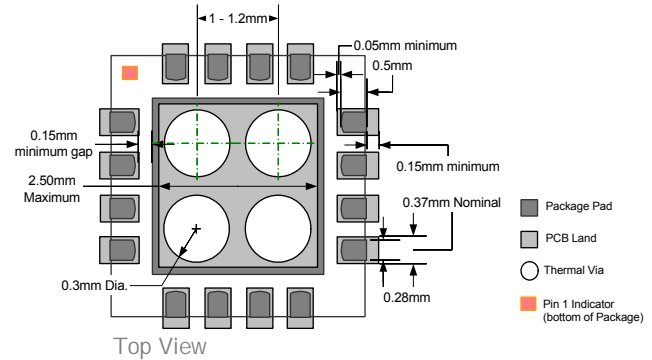
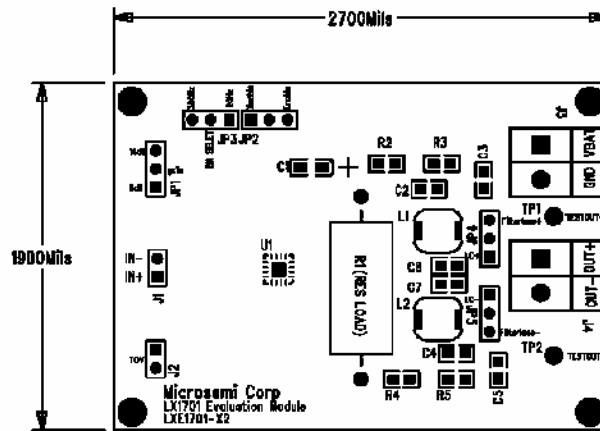
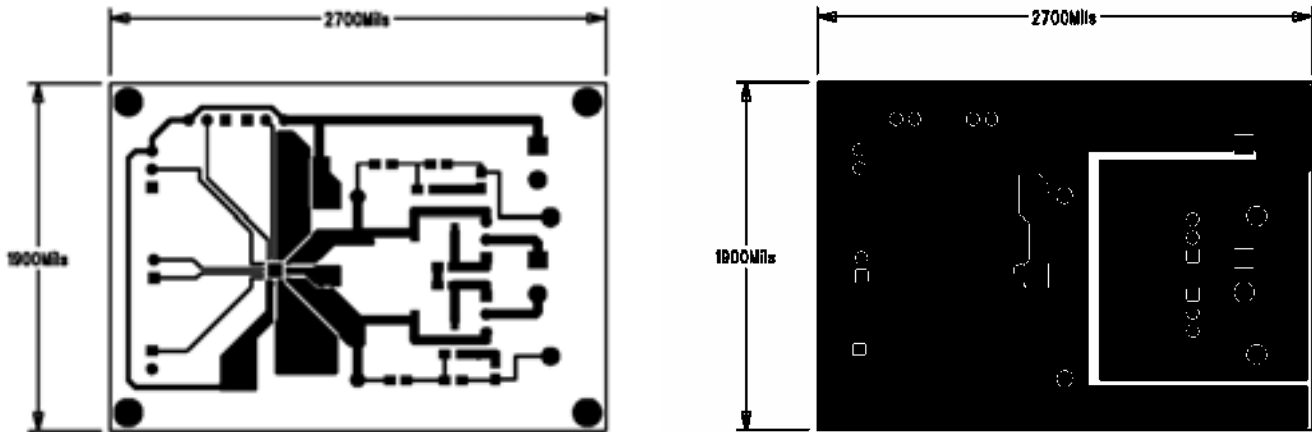
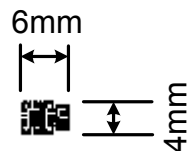
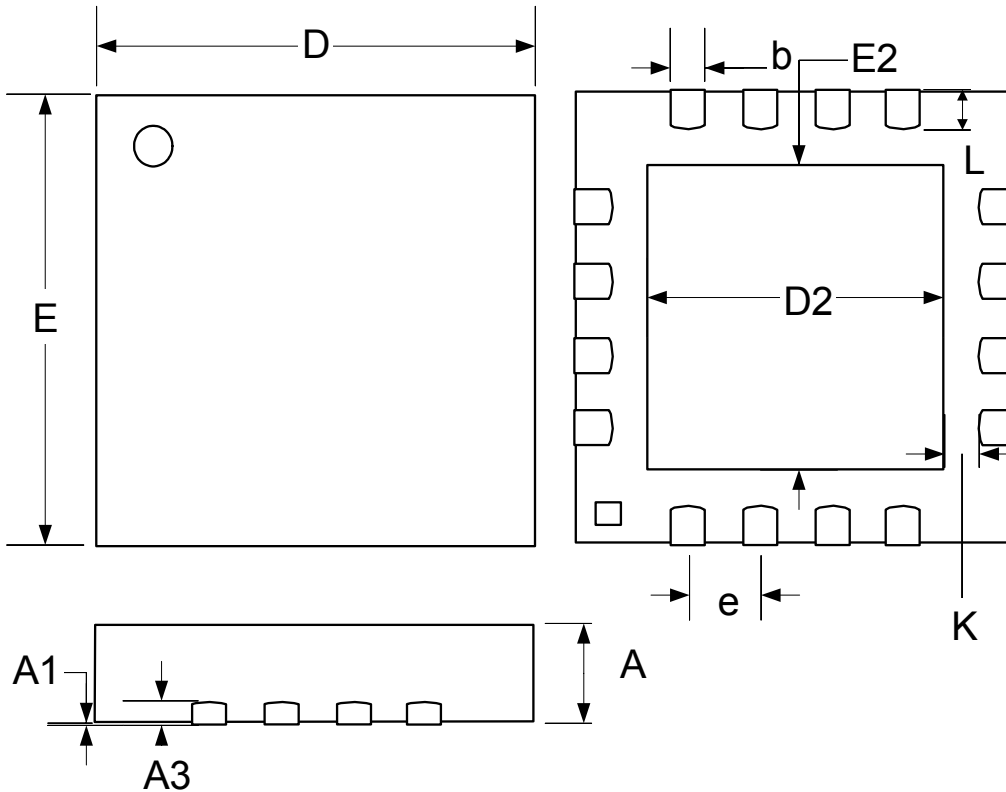

Figure 8 – Recommended Land Pad with Vias for LQ16

APPLICATION INFORMATION

Figure 9 – LXE1701 Evaluation Module PCB Layout

Figure 10 – LX1701 real PCB area with decoupling capacitor

PACKAGE DIMENSIONS
LQ 16-Pin MLPQ Plastic (4x4mm EP / 114x114Cu Exposed Pad)

Dim	MILLIMETERS		INCHES	
	MIN	MAX	MIN	MAX
A	0.80	1.00	0.031	0.039
A1	0	0.05	0	0.002
A3	0.2 REF		0.008 REF	
b	0.23	0.38	0.009	0.015
D	4.00 BSC		0.157 BSC	
E	4.00 BSC		0.157 BSC	
e	0.65 BSC		0.026 BSC	
D2	2.55	2.80	0.100	0.110
E2	2.55	2.80	0.100	0.110
K	0.20	-	0.008	-
L	0.30	0.50	0.012	0.020

Note:

1. Dimensions do not include mold flash or protrusions; these shall not exceed 0.155mm(.006") on any side. Lead dimension shall not include solder coverage.



Microsemi[®]

TM

LX1701

2W Filterless Mono Class-D Audio Amplifier

PRODUCTION DATA SHEET

NOTES

PRODUCTION DATA – Information contained in this document is proprietary to Microsemi and is current as of publication date. This document may not be modified in any way without the express written consent of Microsemi. Product processing does not necessarily include testing of all parameters. Microsemi reserves the right to change the configuration and performance of the product and to discontinue product at any time.