

**TEST AND MEASUREMENT PRODUCTS****Description**

E42X7 is a family of Dual Channel Parametric Measurement Units (PMU) designed for automated test equipment and instrumentation. Manufactured in a wide voltage Bi-CMOS process, it is a monolithic solution for a per-pin PMU.

The E42X7 family consists of three products:

**E4287**

- 16.25V I/O range
- 4 current ranges up to  $\pm 40$  mA
- Analog mux for providing a FLASH™ programming level
- Driven guard pin

**E4257**

- 16.25V I/O range
- 4 Current ranges up to  $\pm 40$  mA
- Small 9mm x 9mm footprint

**E4237**

- 16.25V I/O range
- 2 current ranges up to  $\pm 4$  mA
- Low capacitance for use in relayless tester architectures

Every member of the E42X7 family can drive capacitive loads of up to 300 pF with no external compensation components. A user selectable FORCE amplifier compensation switch allows users to add compensation components for stability with larger capacitive loads.

Integrated voltage clamp circuitry provides a method for clamping DUT (Device Under Test) compliance voltage and protecting the DUT from damage.

Each channel of the E42X7 also features an on-board window comparator that can be used to determine if a measurement value is within a user defined range for go/no-go testing.

Also included with the E42X7 are a number of integrated switches that allow the connection of a central "system" PMU to the E42X7 FORCE and SENSE pins and allow the E42X7 to provide "pull-up" or "pull-down" resistors and termination voltages for DUTs with open element outputs.

The E42X7 is designed to be a low power, low cost, small footprint solution to allow high pin count testers to support a PMU per-pin.

**Features**

- Four Quadrant Operation (FV/MI, FV/MV, FI/MV, FI/MI)
- 4 Current Ranges ( $\pm 40$   $\mu$ A,  $\pm 400$   $\mu$ A,  $\pm 4$  mA,  $\pm 40$  mA) (**E4287, E4257**)
- 2 Current Ranges ( $\pm 40$   $\mu$ A and  $\pm 4$  mA) (**E4237**)
- Wide Output Voltage Range
  - $-3.25$ V to  $+13$ V @ RF pin across all ranges
  - $-3.25$ V to  $\pm 13$ V @ FORCE Pin (Ranges A, B, C)
  - $-1.25$ V to  $+11$ V @ FORCE (Range D)
- Low Power Dissipation
- FV Linearity to  $\pm 0.025\%$  FSVR
- Extremely Fast Settling Times offer reduced test times/increased tester thru-put.
- Central PMU Switches for External PMU,  $-4.75$  V to  $+14.5$ V,  $\pm 40$  mA Ranges
- Switches for Pin Driver Super Voltages
- Driven Guard Output (**E4287**)
- Test Head Ground Reference
- Stable with up to 300 pF Capacitive Loading with no external compensation capacitors
- Switchable Compensation allows stability with up to 10 nF Capacitive Loading
- 14x14 mm, 80 Pin MQFP Package (**E4287**)
- Small, 9x9 mm, 64-Pad LPCC Package (**E4237, E4257**)

**Applications**

- Automated Test Equipment
  - Memory Testers
  - Logic Testers
  - Mixed Signal Testers
  - SOC Testers
- Instrumentation

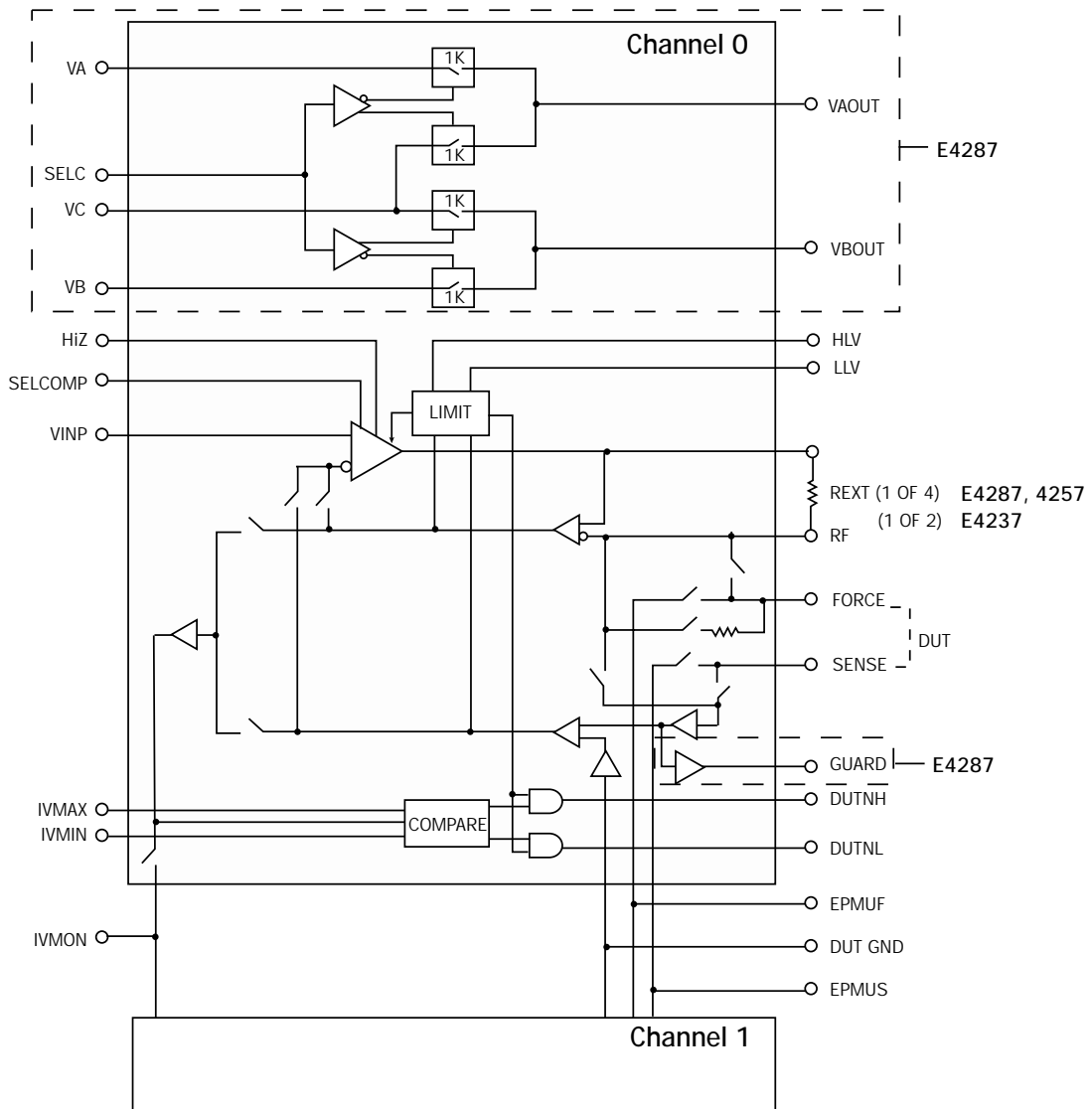

[0] refers to Channel 0, [1] refers to Channel 1

Pin Name	Pin #	Description
<b>PMU</b>		
VINP[0:1]	50, 11	Analog voltage input which programs the output voltage or current of the PMU.
FORCE[0:1]	59, 2	Analog output pin which forces current or voltage.
SENSE[0:1]	58, 3	Analog input pin which senses voltage.
GUARD[0:1]	52, 9	Driven guard output.
DUTGND	66	Device Under Test (DUT) ground reference input to both channels.
FV/FI*[0:1], MI/MV*[0:1]	37, 24 36, 25	Digital inputs which determine whether the PMU is forcing voltage or forcing current, measuring current or measuring voltage.
RSO, RS1[0:1]	45, 16, 46, 15	Digital inputs which select one of the four current ranges.
RF, RA, RB, RC, RD[0:1]	57, 4, 53, 8, 54, 7, 55, 6, 56, 5	Pins to resistors corresponding to ranges A through D. RF common pin to the resistors.
IVMIN[0:1] IVMAX[0:1]	63, 78 62, 79	Analog input voltages which establish the lower and upper threshold level for the measurement comparator.
DUTNH[0:1] DUTNL[0:1]	42, 19 39, 22	Digital comparator outputs that indicate the DUT measurement is less than the upper threshold (not high) and greater than the lower threshold (not low).
IVMON	75	Analog voltage output that provides a real time monitor of either the measured voltage or measured current level for the selected channel.
DISMON[0:1]	35, 26	Digital input which disables IVMON output.
HLV[0:1], LLV[0:1]	64, 77 65, 76	Analog input voltage that establishes the upper voltage clamp level. Analog input voltage that establishes the lower voltage clamp level.
HIZ[0:1]	38, 23	Digital input which places the FORCE output into high impedance.
COMP1[0:1], COMP2[0:1]	51, 10 49, 12	Compensation pins that require an external capacitor connected between COMP1 and COMP2.
SELCOMP[0:1]	34, 27	Digital input selects an internal or external compensation capacitor.

**TEST AND MEASUREMENT PRODUCTS**
**E4287 PIN Description (*continued*)**

[0] refers to Channel 0, [1] refers to Channel 1

Pin Name	Pin #	Description
<b>External PMU</b>		
EPMUF	70	External PMU force input to both channels.
EPMUS	71	External PMU sense input to both channels.
SELIPMU[0:1]	44, 17	Digital input that switches internal PMU to FORCE/SENSE.
SELEPMU[0:1]	43, 18	Digital input that switches external PMU to FORCE/SENSE.
<b>Analog MUX</b>		
VA[0:1]	31, 30	Voltage A switch analog input.
VAOUT[0:1]	69, 72	Voltage A output.
VB[0:1]	32, 29	Voltage B switch analog input.
VBOUT[0:1]	68, 73	Voltage B output.
VC[0:1]	33, 28	Voltage C switch analog input.
SELC[0:1]	47, 14	Digital inputs to select C switches.
<b>Power Supplies</b>		
VCC[0:1]	60, 61, 1, 80	PMU positive analog power supply.
SVCC	74	Switch positive analog power supply to both channels.
VEE[0:1]	40, 41, 20, 21	Negative analog power supply.
AGND	67	Analog ground to both channels.
VDD	13	Positive digital power supply to both channels.
DGND	48	Digital ground to both channels.

80 Pin INT\_TEP\_MQFP Package  
(w/Internal Heat Spreader)  
14mm x 14mm X 2.0mm

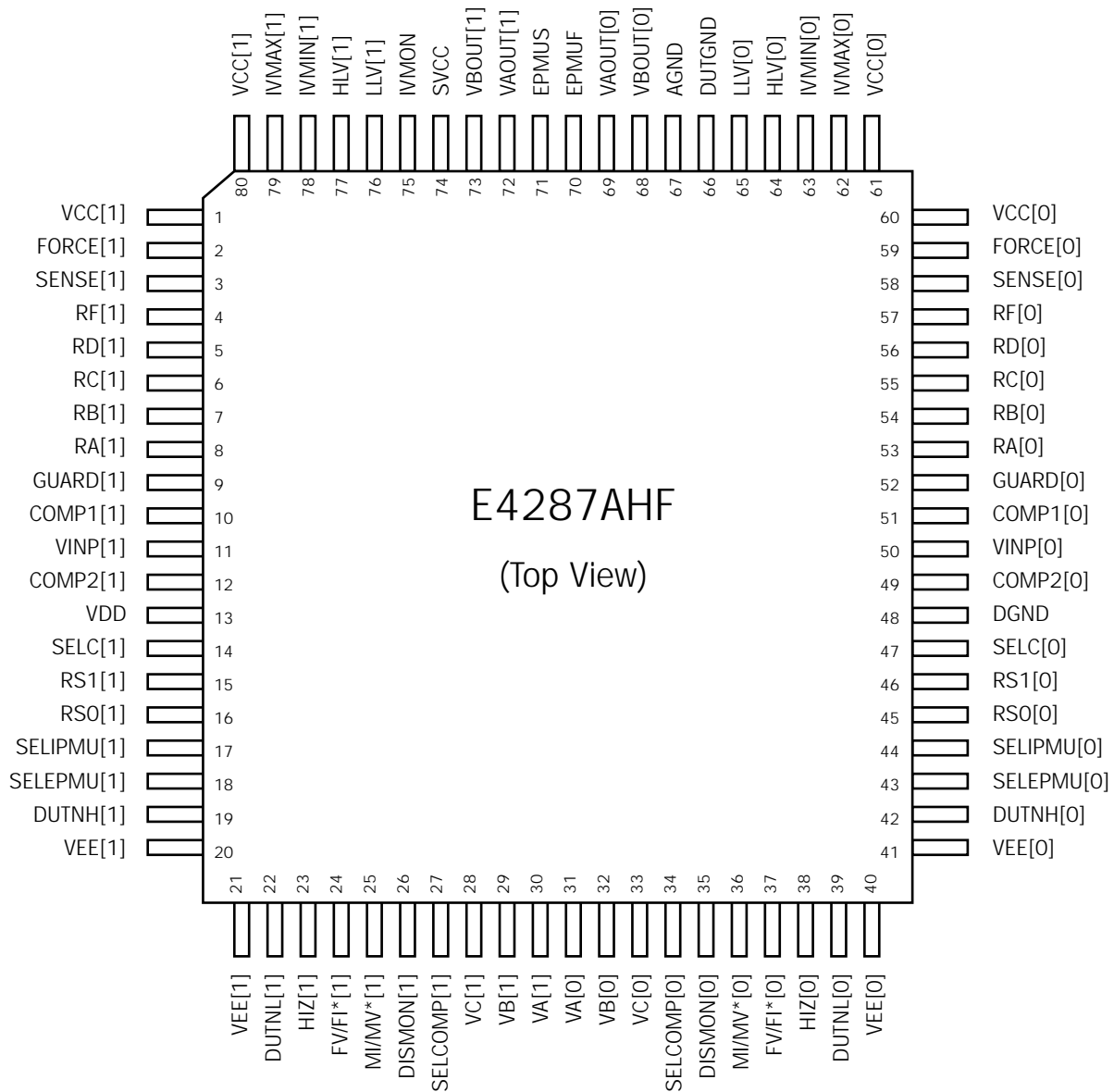

**TEST AND MEASUREMENT PRODUCTS**
**E4257 PIN Description**

[0] refers to Channel 0, [1] refers to Channel 1

Pad Name	Pad #	Description
<b>Internal PMU</b>		
VINP[0:1]	9, 40	Analog voltage input which programs the output "FORCE" voltage or current.
FORCE[0:1]	1, 48	Analog output pin which forces current or voltage.
SENSE[0:1]	2, 47	Analog input pin which senses voltage.
DUTGND	59	Device Under Test (DUT) ground reference input to both channels.
FV/FI*[0:1]	20, 29	Digital inputs which determine whether the PMU is forcing voltage or current.
MI/MV*[0:1]	21, 28	
RS0[0:1]	13, 36	Digital inputs that select one of four current ranges.
RS1[0:1]	12, 37	
RA RB, RC, RD, RF[0:1]	7, 6, 5, 4, 3, 42, 43, 44, 45, 46	Pins to resistors corresponding to ranges A through D. RF common pin to the resistors.
IVMIN[0:1]	62, 51	Analog input voltages which establish the lower and upper threshold level for the measurement comparator.
IVMAX[0:1]	63, 50	
DUTNH[0:1]	16, 33	Digital outputs that indicate the DUT measurement is less than the upper threshold (not high) and greater than the lower threshold (not low).
DUTNL[0:1]	18, 31	
IVMON	54	Analog voltage output that provides a real time monitor of either the measured voltage or measured current level for the selected channel.
DISMON[0:1]	22, 27	Digital input which disables IVMON output.
HLV[0:1]	61, 52	Analog voltage input that establishes the upper voltage clamp level.
LLV[0:1]	60, 53	Analog voltage input that establishes the lower voltage clamp level.
HIZ[0:1]	19, 30	Digital input which places the FORCE output into high impedance.
COMP1[0:1], COMP2[0:1]	8, 41 10, 39	Compensation pins that require an external capacitor connected between COMP1 and COMP2.
SELCOMP[0:1]	23, 26	Digital input selects an internal or external compensation capacitor.
<b>External PMU</b>		
EPMUF	57	External PMU force input to both channels.
EPMUS	56	External PMU sense input to both channels.
SELIPMU[0:1]	14, 35	Digital input that switches internal PMU to FORCE/SENSE.
SELEPMU[0:1]	15, 34	Digital input that switches external PMU to FORCE/SENSE.
<b>Power Supplies</b>		
VCC[0:1]	64, 49	PTU positive analog power supply.
SVCC	55	Switch positive analog power supply.
VEE[0:1]	17, 32	Negative analog power supply.
AGND	58	Analog ground.
VDD	38	Positive digital power supply.
DGND	11	Digital ground.
<b>Thermal Diode String</b>		
VCO	24	Connected to Cathode of the thermal diode string.
VC1	25	Connected to Anode of the thermal diode string.

64-Pad LPCC 9mmx 9mm

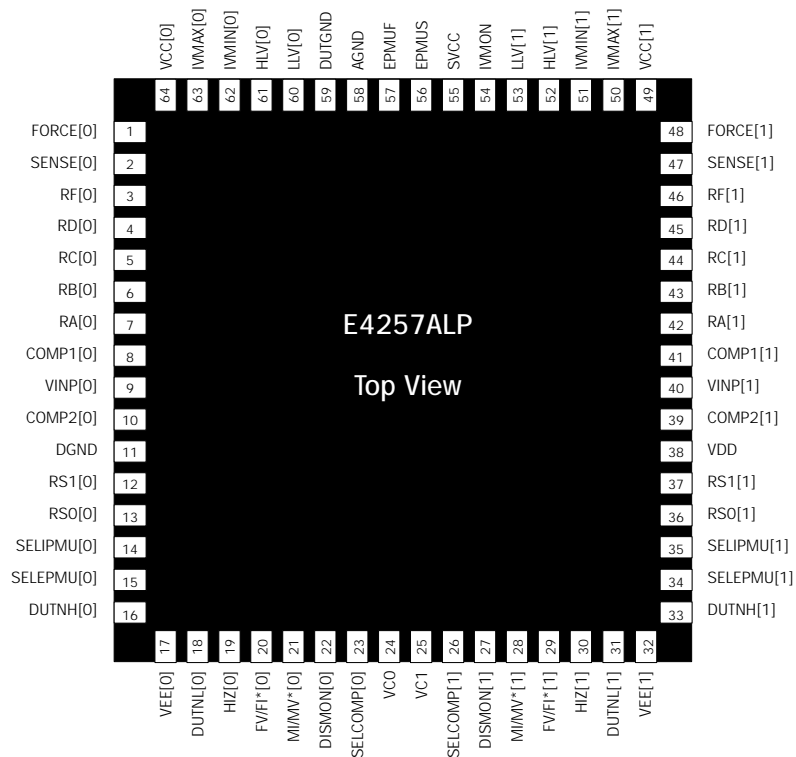
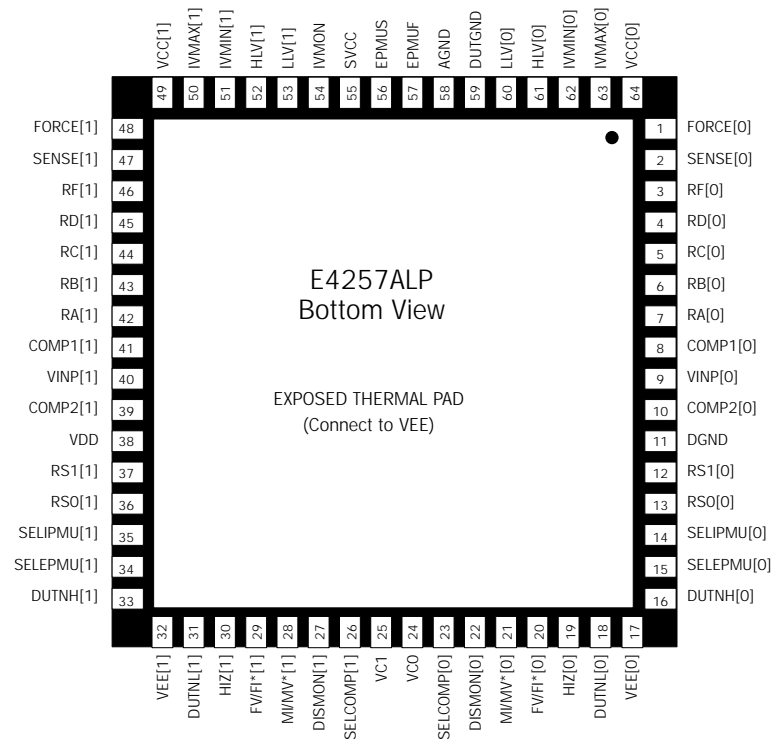

**TEST AND MEASUREMENT PRODUCTS**
**E4237 PIN Description**

Pad Name	Pad #	Description
<b>Internal PMU</b>		
VINP[0:1]	9, 40	Analog voltage input which programs the output "FORCE" voltage or current.
FORCE[0:1]	1, 48	Analog output pin which forces current or voltage.
SENSE[0:1]	2, 47	Analog input pin which senses voltage.
DUTGND	59	Device Under Test (DUT) ground reference input to both channels.
FV/FI*[0:1] MI/MV*[0:1]	20, 29 21, 28	Digital inputs which determine whether the PMU is forcing voltage or current.
RS[0:1]	13, 36, 12, 37	Digital inputs that select one of two current ranges (connect together externally).
RA, RC, RF[0:1]	7, 5, 3, 42, 44, 46	Pins to resistors corresponding to ranges A and C. RF common pin to the resistors.
IVMIN[0:1] IVMAX[0:1]	62, 51 63, 50	Analog input voltages which establish the lower and upper threshold level for the measurement comparator.
DUTNH[0:1] DUTNL[0:1]	16, 33 18, 31	Digital outputs that indicate the DUT measurement is less than the upper threshold (not high) and greater than the lower threshold (not low).
IVMON	54	Analog voltage output that provides a real time monitor of either the measured voltage or measured current level for the selected channel.
DISMON[0:1]	22, 27	Digital input which disables IVMON output.
HLV[0:1] LLV[0:1]	61, 52 60, 53	Analog voltage input that establishes the upper voltage clamp level. Analog voltage input that establishes the lower voltage clamp level.
HIZ[0:1]	19, 30	Digital input which places the FORCE output into high impedance.
COMP1[0:1], COMP2[0:1]	8, 41 10, 39	Compensation pins that require an external capacitor connected between COMP1 and COMP2.
SELCOMP[0:1]	23, 26	Digital input selects an internal or external compensation capacitor.
<b>External PMU</b>		
EPMUF	57	External PMU force input to both channels.
EPMUS	56	External PMU sense input to both channels.
SELIPMU[0:1]	14, 35	Digital input that switches internal PMU to FORCE/SENSE.
SELEPMU[0:1]	15, 34	Digital input that switches external PMU to FORCE/SENSE.
<b>Power Supplies</b>		
VCC[0:1]	64, 49	PTU positive analog power supply.
SVCC	55	Switch positive analog power supply.
VEE[0:1]	17, 32	Negative analog power supply.
AGND	58	Analog ground.
VDD	38	Positive digital power supply.
DGND	11	Digital ground.
<b>Thermal Diode String</b>		
VCO	24	Connected to Cathode of the thermal diode string.
VC1	25	Connected to Anode of the thermal diode string.
N/C	4, 6, 43, 45	Not connected.



64-Pad LPCC 9mmx 9mm

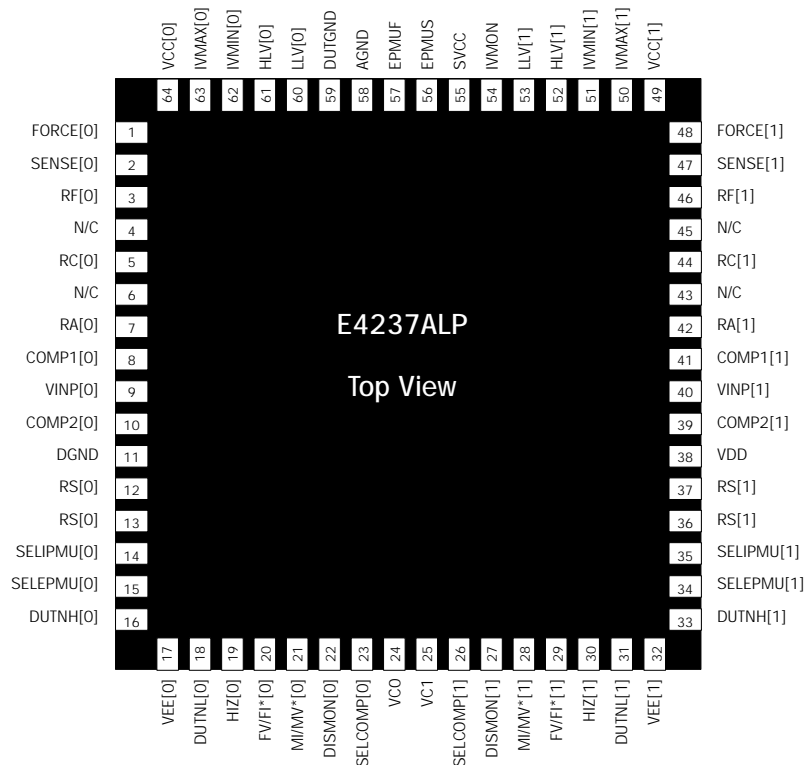
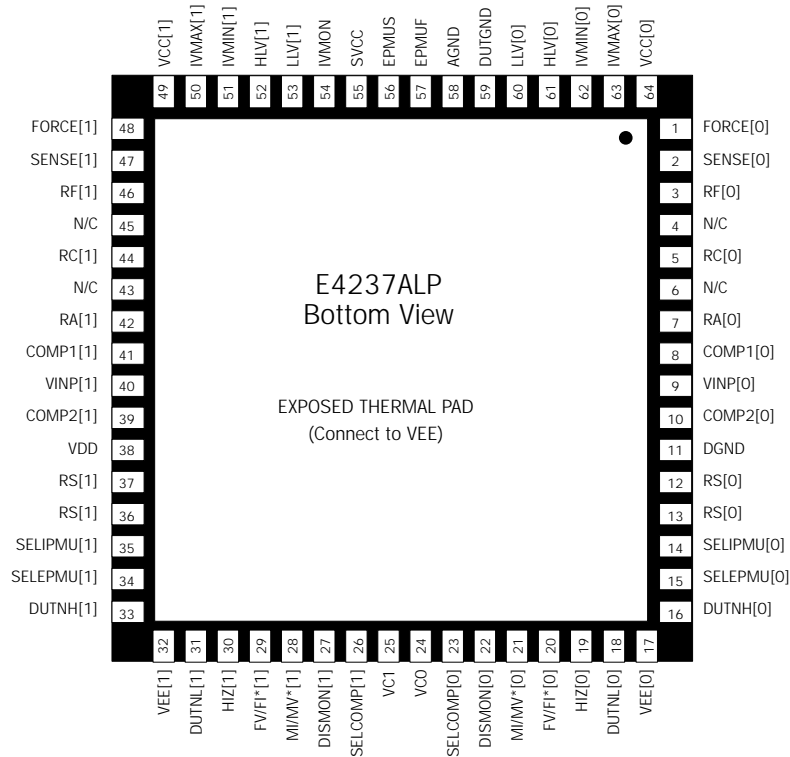

## TEST AND MEASUREMENT PRODUCTS

### Circuit Description

#### Circuit Overview

E42X7 is a family of dual channel parametric test and measurement units, each of which can:

- Force Voltage/Measure Current
- Force Current/Measure Voltage
- Force Voltage/Measure Voltage
- Force Current/Measure Current

Each PMU channel can force or measure voltage over a 16.25V range and force or measure current over four distinct ranges:

#### E4257, E4287

- ± 40  $\mu$ A
- ± 400  $\mu$ A
- ± 4 mA
- ± 40 mA

#### E4237

- ± 40  $\mu$ A
- ± 4 mA

The E42X7 also features integrated voltage clamp/over-voltage detection circuitry that provides over-voltage protection to the DUT (Device Under Test) during normal operation. Short-circuit protection circuitry protects the E42X7 by limiting the maximum output current to a specified value over the full-scale current for a particular range. The E4287 features an integrated analog MUX that is intended to be used to toggle the “driver high level” supplied to a pin electronics driver between normal logic levels and a super voltage level which is suitable for programming devices that require a “third-level” such as FLASH™.

The E4287 also features a pin (per channel), GUARD, which can be used to drive the guard traces of a FORCE/SENSE pair. By surrounding FORCE and SENSE traces with guard traces which connect to the GUARD pin, an effective method to achieve minimal leakage can be achieved.

The E42X7 also includes a test head ground (DUTGND) referencing features which allow the force voltage function to be referenced to a separate ground reference other than the ground (GND) power used for the device.

Also included with the E42X7 are a number of integrated switches that allow the device to be configured to:

- Connect a central “system” PMU to the DUT through the FORCE and SENSE pins of the E42X7.
- Provide a ~4.5K $\Omega$  pull-up resistor to the programmed force voltage level, which allows devices with unipolar open-element outputs (i.e., open drain) to be tested without providing a designated pull-up or pull-down on a load board.

#### PPMU Functionality

The trapezoid in Figure 1 describes the V/I functionality of the E42X7’s internal PMU when a DUT is connected to the FORCE or RF pins (a functional schematic of the E42X7 can be viewed in Figure 2).

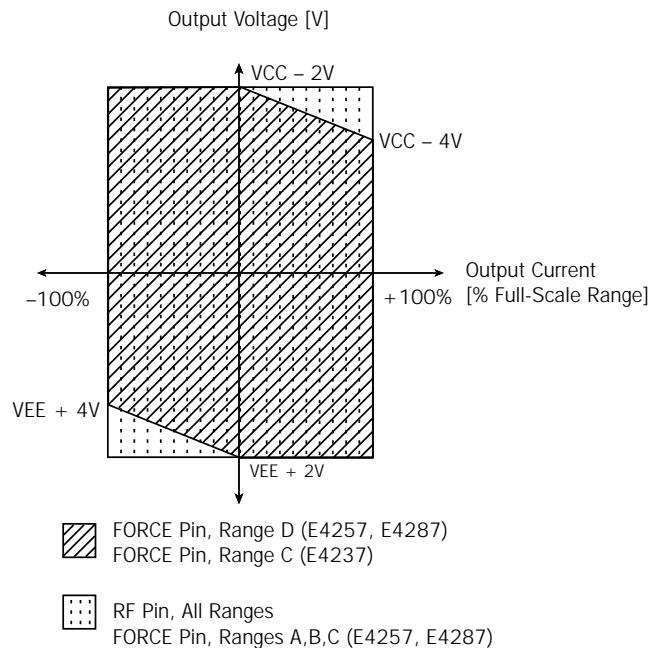

**Figure 1. PMU Functionality/Range at the FORCE and RF Pins**

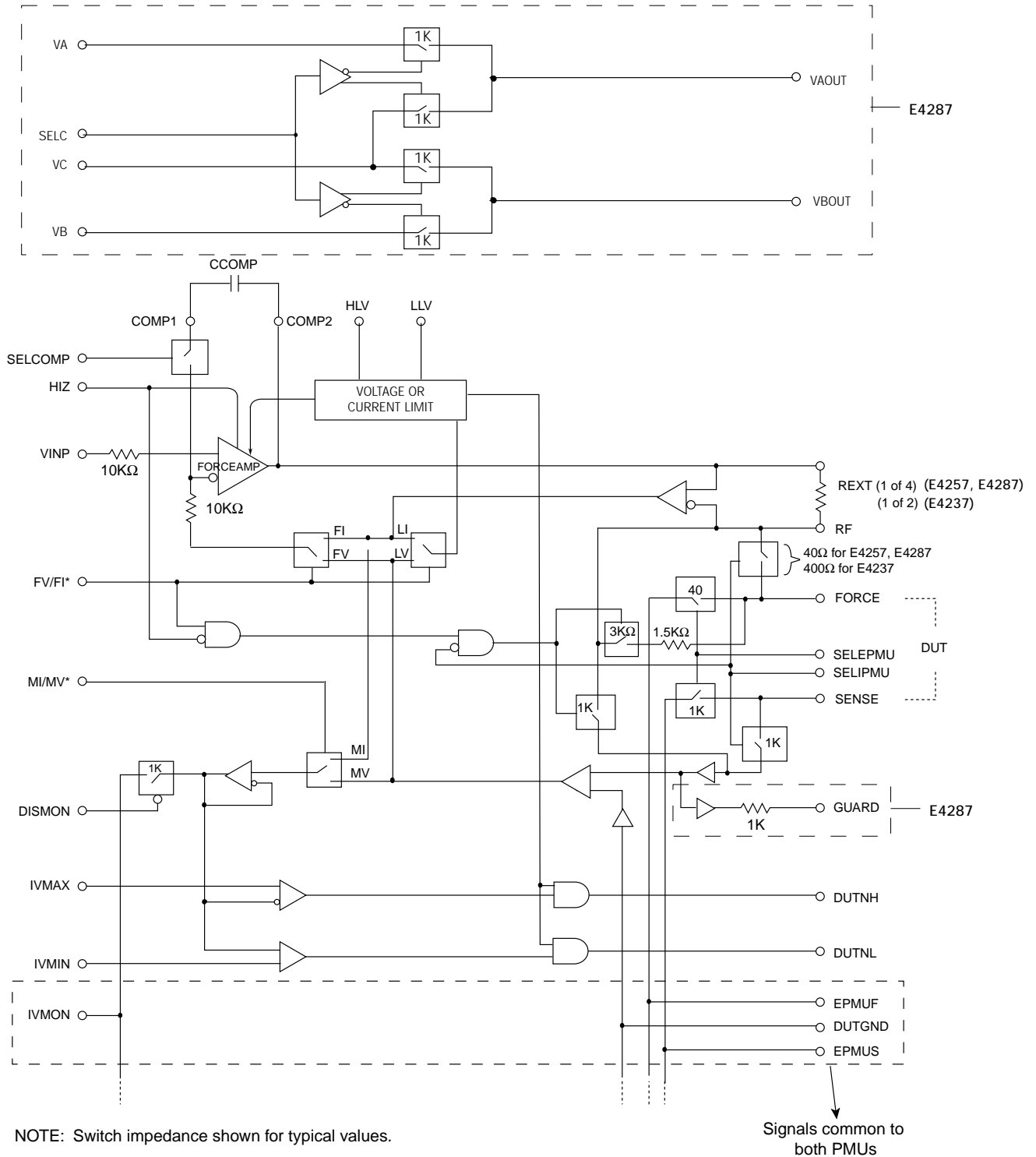

Figure 2. PMU Functionality/Range at the FORCE and RF Pins

TEST AND MEASUREMENT PRODUCTS

Circuit Description (continued)

**Control Inputs**

All control inputs are CMOS compatible with characteristics as defined in the "Digital Inputs" section of the specification table.

**FV/FI\*** is a digital input which determines whether the PMU forces current or voltage, and **MI/MV\*** is a Digital input which determines whether the PMU measures current or voltage. FV/FI\* and MI/MV\* are independent for each channel.

**HiZ** is a digital input that is used to place the PMU's force amp into a high impedance state. Table 1 describes the modes of operation related to these three input pins.

HiZ	FV/FI*	MI/MV*	Mode of Operation
1	X	X	High Impedance
0	0	0	Force Current, Measure Voltage
0	0	1	Force Current, Measure Current
0	1	0	Force Voltage, Measure Voltage
0	1	1	Force Voltage, Measure Current

Table 1.

**RS0** and **RS1** are digital inputs to an internal analog MUX which selects an external resistor corresponding to a desired current range. The truth table for RS0 and RS1, along with the associated external resistor values and current ranges, is shown in Table 2. RS0 and RS1 are independent for each channel of the E4287 and E4257. RS0 and RS1 for each channel should be connected together externally on the E4237.

RS0	RS1	Range	Current Range (Max)	"Nominal" Ext. R	
0	0	A	±40 µA	RA = 12.4KΩ	
0	1	B	±400 µA	RB = 1.24KΩ	E4257, E4287
1	1	C	±4 mA	RC = 124Ω	
1	0	D	±40 mA	RD = 12.4Ω	E4257, E4287

Table 2.

**SELCOMP** is a digital input pin that is used to switch external capacitance in parallel with the E42X7's internal compensation in order to stabilize the force amplifier (see Figure 1) in situations where a large capacitive loading condition exists on the FORCE pin (such as during system calibration). SELCOMP functionality is illustrated in Table 3.

SELCOMP	Force Amplifier Compensation
0	Internal
1	Internal + CCOMP

Table 3.

**SELIPMU** is a digital input that is used to change the connectivity of the FORCE/SENSE pair of each channel such that the force amplifier's output/feedback is routed directly to the FORCE/SENSE pins or through an ~4.5KΩ integrated pull-up resistance path. SELIPMU functionality is described in Table 4.

SELIPMU	Force Amplifier Connectivity
0	Force amplifier output can be connected to the FORCE pin through ~4.5KΩ pull-up resistance if FV/FI* = 1 and HiZ=0 (see On-Chip Termination Mode section)
1	FORCE amplifier output connected to the FORCE pin through ~40Ω resistance (force amplifier controls the FORCE/SENSE node)

Table 4. SELIPMU Functionality

**SELEPMU** is a digital input that is used to connect an external (system) PMU to FORCE/SENSE pins as may be done during calibration of the device in a typical ATE application. SELEPMU functionality is described below in Table 5.

Circuit Description *(continued)*

SELEPMU	External PMU Connectivity
0	EPMUF and EPMUS pins are disconnected from the FORCE and SENSE pins.
1	EPMUF is connected to FORCE through $\sim 40\Omega$ of resistance, and EPMUS is connected to SENSE through $\sim 1K\Omega$ of resistance.

**Table 5. SELEPMU Functionality**

**SELC** is a digital input pin that is used to control the analog mux section of the E4287 and select between the normal logic level used in an application and the super voltage level so that the desired pin electronics driver levels are channeled through the E4287 to the pin driver. SELC functionality is described in Table 6.

SELC	VAOUT	VBOUT
0	VA	VB
1	VC	VC

**Table 6. Analog Mux Functionality (E4287 only)**

**DISMON** is a digital input pin that is used to select the desired PMU measurement channel that appears at IVMON, or to place the IVMON pin in a high impedance state. DISMON functionality is described in Table 7.

**IVMON**

IVMON is an analog output pin which displays the measured parameter (i.e. compliance voltage or compliance current) from the channel selected using DISMON. The relationship between DISMON, MI/MV\*, and the parameter displayed at IVMON is illustrated in Table 7.

DISMON		MI/MV*		IVMON
[0]	[1]	[0]	[1]	
0	0	X	X	High Impedance
1	1	X	X	High Impedance (both channels cannot use IVMON at the same time)
0	1	1	X	Measured Current, Channel 0
0	1	0	X	Measured Voltage, Channel 0
1	0	X	1	Measured Current, Channel 1
1	0	X	0	Measured Voltage, Channel 1

**Table 7. IVMON Functionality**

**FORCE/RF/SENSE**

**FORCE** is an analog output pin through which a programmed voltage or current can be applied to the DUT.

**SENSE** is a high impedance analog input that is also connected to the DUT and provides feedback for the Force amplifier (see Figure 1) in “force voltage” mode and measures DUT compliance voltage measurement in the “measure voltage” mode.

**RF** is an analog output pin through which a programmed voltage or current can be supplied to the DUT. Since there is no disconnect switch between the FORCE amplified output and the RF pin, using the RF pin as the PMU output offers extended output voltage capability and full-scale current (note that on-chip termination mode only works when using the FORCE pin).

**Force Voltage (FV) Mode**

In the FV mode ( $FV/FI^* = 1$ ), the force amplifier (see Figure 2) is configured as a unity gain buffer.

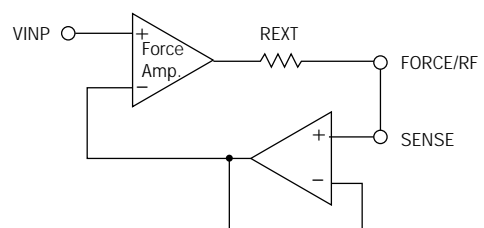

TEST AND MEASUREMENT PRODUCTS

Circuit Description (continued)

In FV mode, VINP is a high impedance analog input that sets the output voltage at the RF and/or FORCE output pins across their specified ranges as follows:

$$V_{FORCE/RF} = V_{VINP} \pm V_{VINP} \times \text{specified Gain Error} \pm \text{specified Offset Voltage} \pm \text{specified Linearity Error}$$

**Force Current (FI) Mode**

In the FI mode (FV/FI\* = 0), the negative feedback to the force amplifier is provided from the output of a 4x gain instrument amplifier that senses the voltage across REXT.

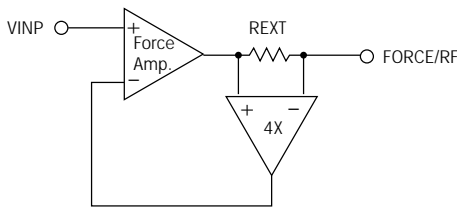

In FI mode, VINP is a high impedance analog input that sets the output current at the RF and/or FORCE pins across their specified compliance voltage ranges as follows:

$$I_{FORCE/RF} = V_{VINP} \times \text{specified FI Gain} \pm \text{specified Offset Current} \pm \text{specified Linearity Error}$$

The nominal relationship between VINP and the current at the FORCE or RF pins is displayed in Table 8.

V <sub>VINP</sub>	I <sub>FORCE/RF</sub>
+2V	+ Full-Scale Current
0V	0
-2V	- Full-Scale Current

Table 8. Nominal Forced Current/V<sub>VINP</sub> Relationship

**Measure Current (MI) Mode**

In the MI mode (MI/MV\* = 1), the current through REXT is sensed using a 4x gain instrument amplifier, and the resulting measurement can be tested using the on-chip window comparator or routed to the IVMON pin.

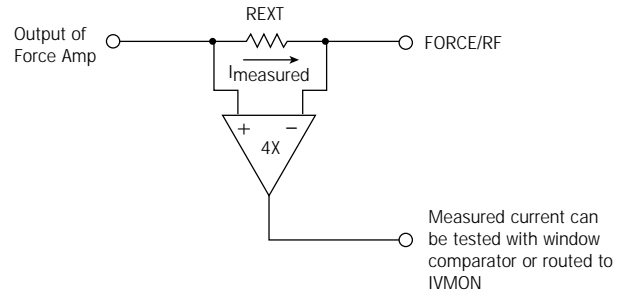

In the MI mode, the voltage displayed at IVMON relates to the current measured through REXT as follows:

$$V_{IVMON} = I_{measured} \pm \text{Specified Linearity Error} \times \text{specified MI Gain} \pm \text{specified Offset Current}$$

The nominal relationship between the current measured (I<sub>measured</sub>) and the voltage displayed at IVMON is depicted in Table 9.

I <sub>measured</sub>	V <sub>IVMON</sub>
+ Full-Scale Current	+2V
0	0V
- Full-Scale Current	-2V

Table 9. Nominal V<sub>IVMON</sub>/I<sub>measured</sub> Relationship

**Measure Voltage (MV) Mode**

In the MV mode (MI/MV\* = 0), DUT compliance voltage is monitored using the SENSE pin, and the resulting measurement can be tested using the on-chip window comparator, or routed to the IVMON pin.

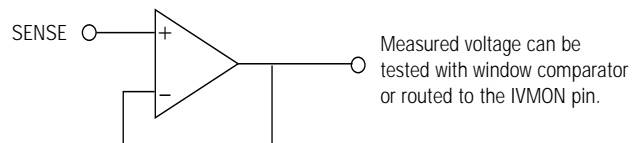

In the MV mode, the voltage monitored at SENSE maps 1:1 with the voltage measured at IVMON as follows:

$$V_{IVMON} = V_{SENSE} \times \text{specified Gain} \pm \text{specified Offset Voltage} \pm \text{specified Linearity Error}$$

**Window Comparator**

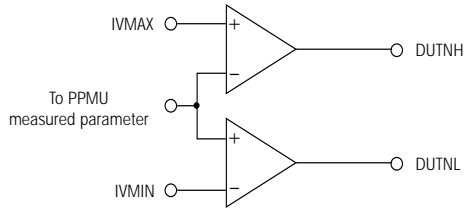

Each channel of the E42X7 features two comparators connected in a “window comparator” topology. These comparators can be used to provide two-bit measurement range classification for go/no-go testing of devices. IVMAX and IVMIN are high impedance analog voltage inputs that establish the upper and lower thresholds for the window comparator. DUTNH and DUTNL are LVTTTL outputs that indicate where a PPMU measured parameter lies in relation to the IVMAX and IVMIN thresholds and are also used to indicate when voltage clamping is taking place during measurement as shown in Table 10.

Condition	DUTNH	DUTNL
Measurement is within the range established by IVMAX and IVMIN	1	1
Measurement is above the range established by IVMAX and IVMIN	0	1
Measurement is below the range established by IVMAX and IVMIN	1	0
V/I Limiting is engaged and having an effect on the measurement	0	0

**Table 10. Comparator Output Truth Table**

**Voltage Clamp**

The integrated voltage clamp circuitry is controlled using the HLV and LLV input pins. HLV and LLV are high impedance analog voltage inputs that establish the “high” and “low” clamp thresholds.

The voltage clamp circuitry will constrain the DUT voltage ( $V_{\text{compliance}}$ ) to within a range determined by the HLV and LLV pins as follows:

$$V_{\text{min}} \leq V_{\text{compliance}} \leq V_{\text{max}}$$

where:  $V_{\text{min}} = V_{\text{LLV}} \pm \text{specified Limit Accuracy}$   
 $V_{\text{max}} = V_{\text{HLV}} \pm \text{specified Limit Accuracy}$

As the voltage clamp circuitry uses the FORCE pin to sense the DUT compliance voltage, applications that connect the RF pin to the DUT (see Applications Information section) must connect the FORCE pin to the RF pin for proper voltage limiting functionality.

In the event of a voltage clamping condition, the DUTNL and DUTNH comparator outputs are designed to “pull-down” to logic “0” in order to indicate that the E42X7 is clamping and may be influencing any measurement that is being made (see Window Comparator section).

**Current Limiting**

The E42X7 features current limiting circuitry that limits the amount of current that the device can delivery through RF or FORCE pins. The amplitude of the short circuit current is a function of the current range selected. The maximum short-circuit current through the FORCE pin is the sum of the force amp current limit and the voltage clamp current limit if the voltage clamp is enabled and engaged.

In the event that the voltage clamp is engaged, and the FORCE pin voltage exceeds the HLV or LLV pin settings by more than ~1.5V, the E42X7 will open all of the internal switches connected to the FORCE and SENSE nodes in order to protect internal PMU circuitry from damage.

**On-Chip “Termination” Mode**

When the E42X7 is placed in FV mode and the internal PMU is not selected (SELIPMU = 0), it can be placed in “termination” mode by setting the HiZ input to logic “0”.

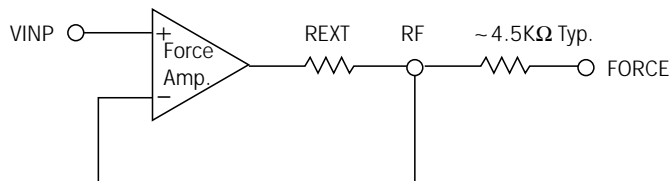

When configured in this manner, the E42X7 can be used to provide an ~4.5KΩ “pull-up” or “pull-down” resistor at the FORCE pin to the termination voltage programmed by V<sub>VINP</sub> for testing devices with unipolar “open-element” outputs (i.e. open drain).

**External PMU**

The E42X7 features on-chip routing and switches for connecting an external PMU to the FORCE and SENSE pins of each channel.

The EPMUF pin is the “External PMU Force” input and is connected to the FORCE pin through an on-chip 40Ω, 40 mA switch.

The EPMUS pin is the “External PMU Sense” input and is used to connect the external PMU’s sense line to the E42X7’s SENSE pin through an on-chip high impedance switch.

The on-chip switches used for routing the external PMU are located in a separate on-chip well that can be separately powered from the core on-chip PMU circuitry using SVCC. This allows the voltage range of the external PMU to be greater than that of the core PMU without increasing core PMU power dissipation.

**NOTE: When using SVCC > VCC to extend the range of the external PMU, care must be taken to ensure that the RF pin voltage does NOT exceed VCC. This can be accomplished by setting SELIPMU=0 to disconnect the RF pin from FORCE, and will also disconnect the internal sense circuitry from the**

**SENSE pin to protect it from over-voltage. The internal PMU should be disabled (HiZ=1) in order to prevent it from initiating pull-up mode.**

**REXT Selection**

The E42X7 is designed for the full-scale voltage drop across REXT (RA, RB, RC, RD) to be ± 0.5V.

Resistor values can be chosen that will enable the E42X7 to operate with full-scale current ranges other than those specified provided the voltage swing across REXT does not exceed ± 0.5V and the full-scale current for each range does not exceed those specified in this datasheet.

**Thermal Diode String**

The E42X7 features an internal diode string connected between the VC[0] and VC[1] pins that can be used to perform device junction temperature measurements as shown in the figure below.

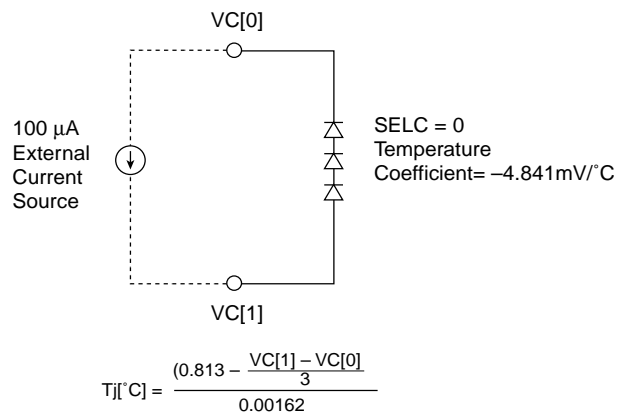



### Common Mode Error/Calibration

In order to attain a high degree of accuracy in a typical ATE application, offset and gain errors are accounted for through software calibration. When operating the E42X7 in the Measure Current (MI) or Force Current (FI) modes, an additional source of error, common mode error, should be accounted for. Common mode error is a measure of how the common mode voltage,  $V_{CM}$ , at the input of the current sense amplifier affects the forced or measured current values (see Figure 3). Since this error is created by internal resistors in the current sense amplifier, it is very linear in nature.

Using the common mode error and common mode linearity specifications, one can see that with a small number of calibration steps (see Applications note PMU-A1), the effect of this error can be significantly reduced.

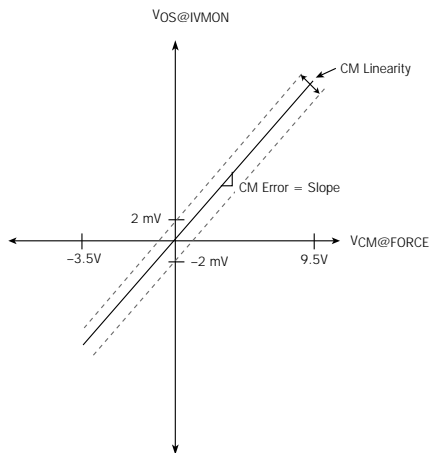

(Note: Slope may be negative)

**Figure 3. Graphical Representation of Common Mode Error**

### Power Supplies

The E42X7 requires four external power supply levels to operate:

- VCC (Positive Analog Supply)
- VEE (Negative Analog Supply)
- SVCC (Switch Supply)
- VDD (Digital Supply)

VCC and VEE provide power to all of the E42X7's internal analog circuitry except for the internal CMOS transmission gates used for the analog mux, external PMU switches, IVMON switches, and the "termination" mode switches. Power to these switches is provided by the SVCC supply. This allows for power savings in that the E42X7 can be used with rail voltages that are less than those that are being switched using the analog mux or external PMU switches. Note that in applications where  $SVCC > VCC$ , care must be taken to ensure that  $SELIPMU = 0$  whenever the FORCE pin voltage exceeds VCC.

### Power Supply Sequencing

In order to avoid the possibility of latch-up, the following power-up requirements **must** be satisfied:

1.  $VEE \leq GND \leq VDD \leq VCC \leq SVCC$  at all times
2.  $VEE \leq \text{All Analog Inputs} \leq VCC$
3.  $GND \leq \text{All Digital Inputs} \leq VDD$

The following sequence can be used as a guideline when powering up the E42X7:

1. VEE (substrate)
2. SVCC
3. VCC
4. VDD
5. Digital Inputs
6. Analog Inputs

The three diode configuration shown in Figure 4 should be used on a once-per-board basis to prevent damage to the PMU in the event of a power supply failure and to ensure that power up requirements are not violated.

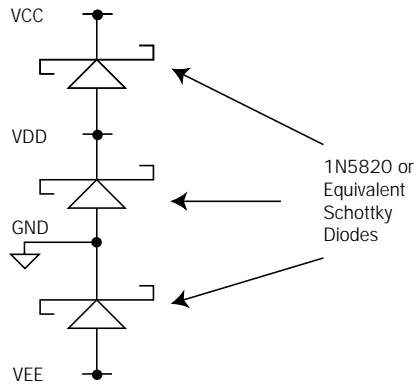

**Figure 4. Power Supply Protection Scheme**

**Warning:** It is extremely important that the voltage on any device pin does not exceed the range of VEE - 0.5 to VCC + 0.5V at any time, either during power up, normal operation, or during power down. Failure to adhere to this requirement could result in latchup of the device, which could be destructive if the system power supplies are capable of supplying large amounts of current. Even if the device is not immediately destroyed, the cumulative damage caused by the stress of repeated latchup may affect device reliability.

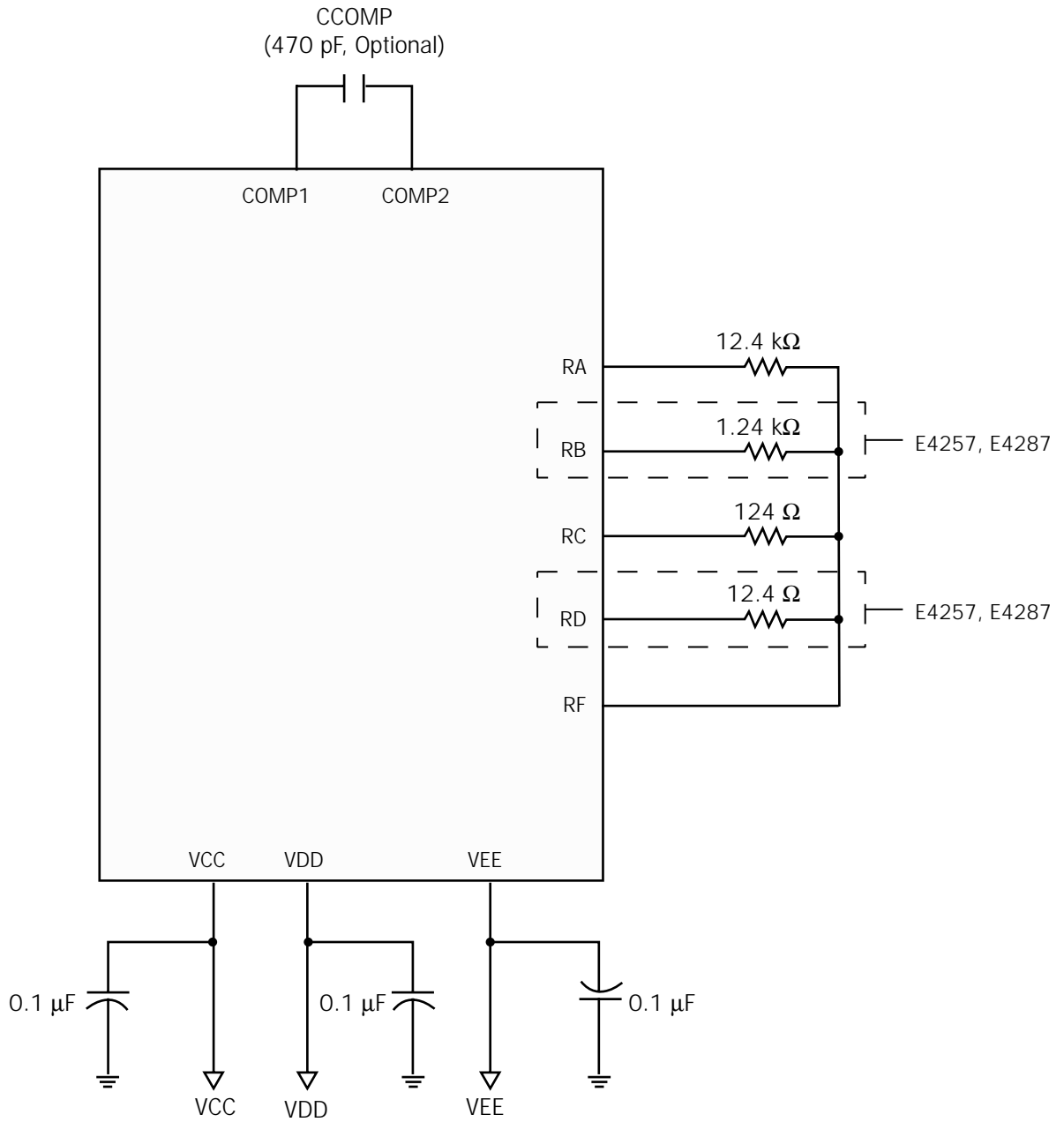
**Required External Components Per PMU**

Actual decoupling capacitor values depend on the system environment.

**Per Pin PMU**

An application of the E42X7 is as a Per-Pin Parametric Measurement Unit (PPMU) in ATE as shown in the figure below. IVMON is connected to an external ADC to perform measurements for either MI or MV. Such measurements can also be used to calibrate the inputs to the comparator.

Typically, IVMONs from multiple PMUs are connected to a single ADC where DISMON is used to select a PPMU.

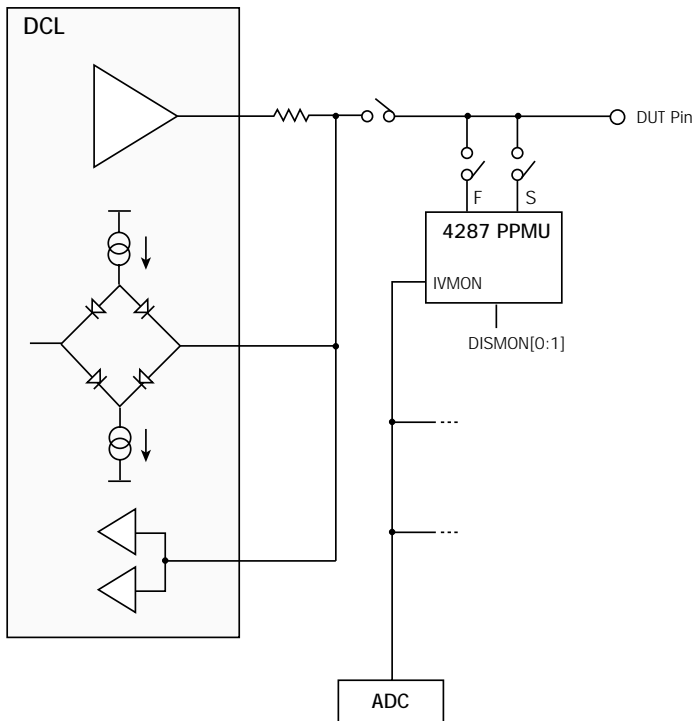

**Connecting the PMU to a DUT Pin**

A Device Under Test (DUT) may be connected to the PPMU either 'locally' or 'remotely' to the pin electronics:

**Local Pin Electronics:**

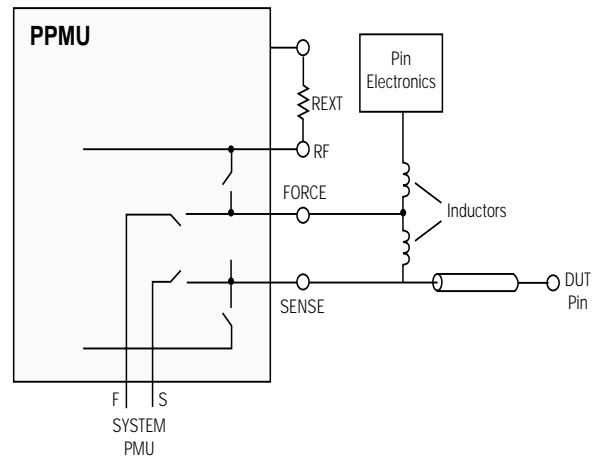

**Remote Pin Electronics (via Relays)**

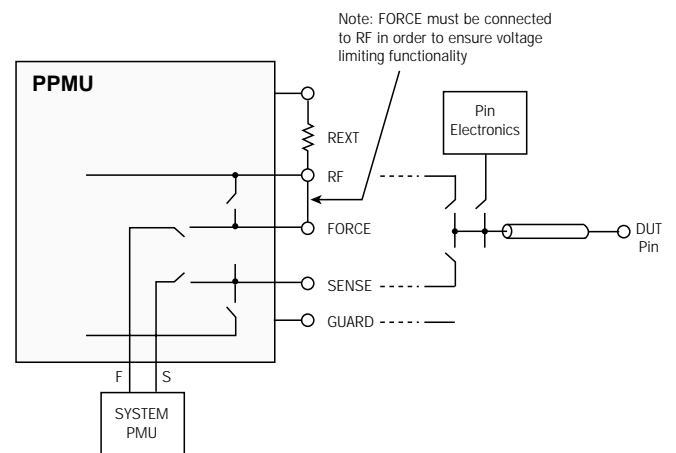

**Use of Switches for Super Voltage (E4287 ONLY)**

An application of the E42X7 switches and switch matrices is to connect their PMU and an external PMU to a DUT pin and to switch a pin electronics driver's levels to a Super Voltage as shown below.

**E4287 ONLY**

In many applications, the external PMU's range may need to exceed that of a pin's PMU (a pin's PMU range may be restricted in order to save power). For example,  $V_{EE} = -5.0V$ ,  $V_{CC} = +8.25V$ ,  $SV_{CC} = +14.75V$  would permit a PMU range of  $-3.25V$ ,  $+6.5V$ , super voltage of  $+12V$ , and an external PMU range of  $-4.75V$ ,  $+14.5V$  (SELIPMU = 0).

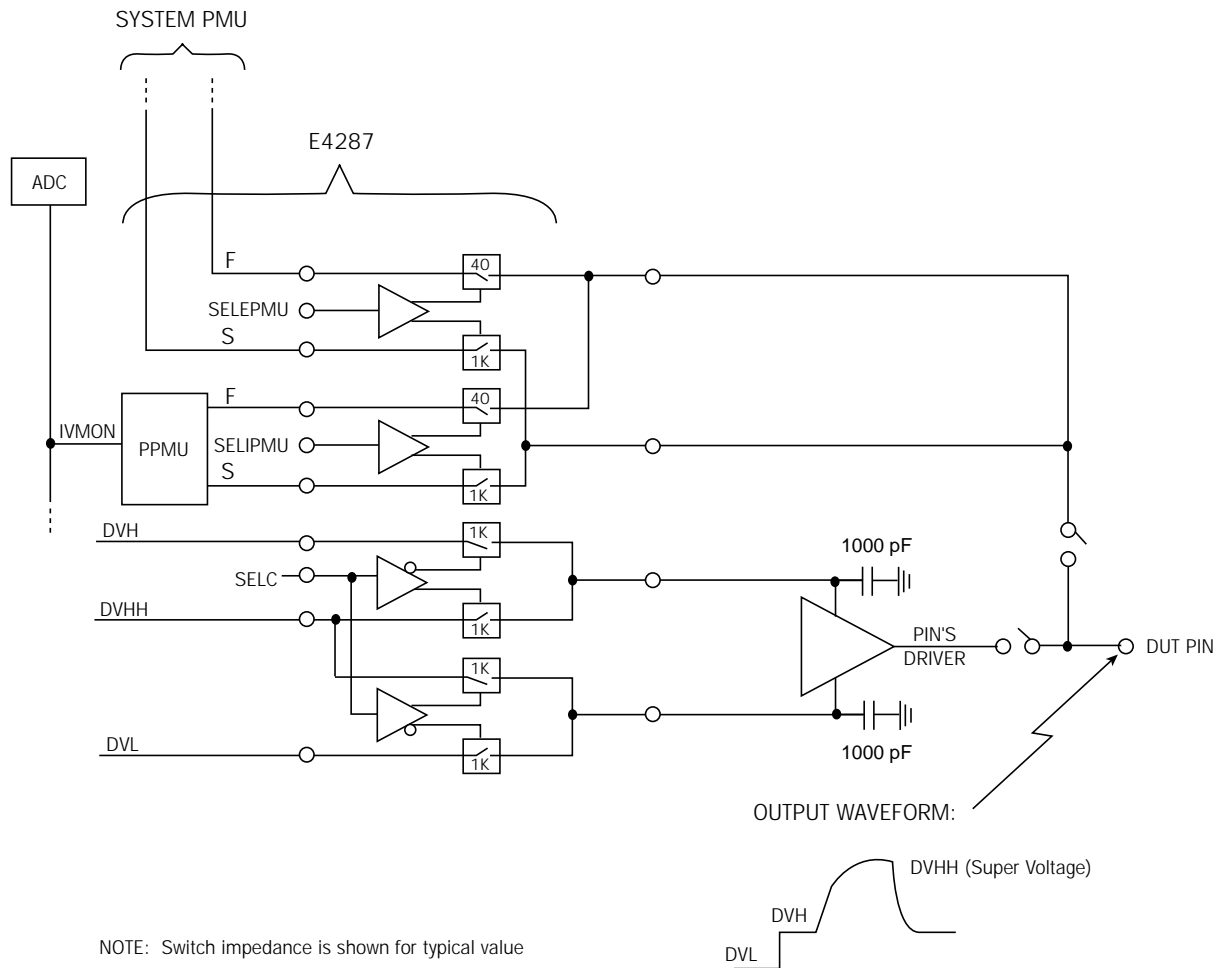

**E42X7 Package: 14 x 14 x 2.0 mm, 80 Pin, Int\_TEP\_MQFP  
(with Internal Heat Spreader)**

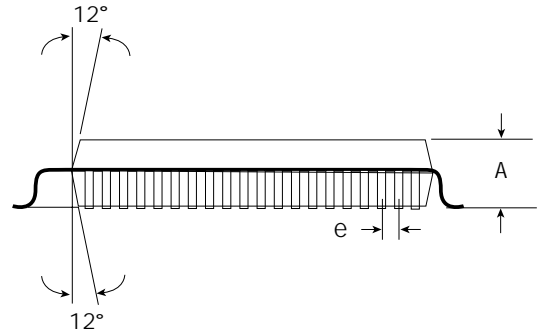
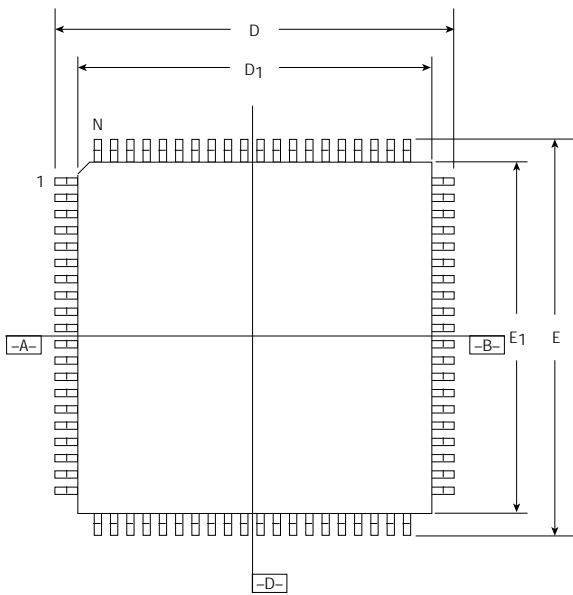

DIMS.	TOL.	
A	MAX	2.35
A1		0.25 Max
A2	+ .10/- .05	2.00
D	± .25	16.00
D1	± .10	14.00
E	± .25	16.00
E1	± .10	14.00
L	+ .15/- .10	.88
e	BASIC	.65
b	± .05	.30
θ		0° - 7°
ddd	MAX	.12
ccc	MAX	.10

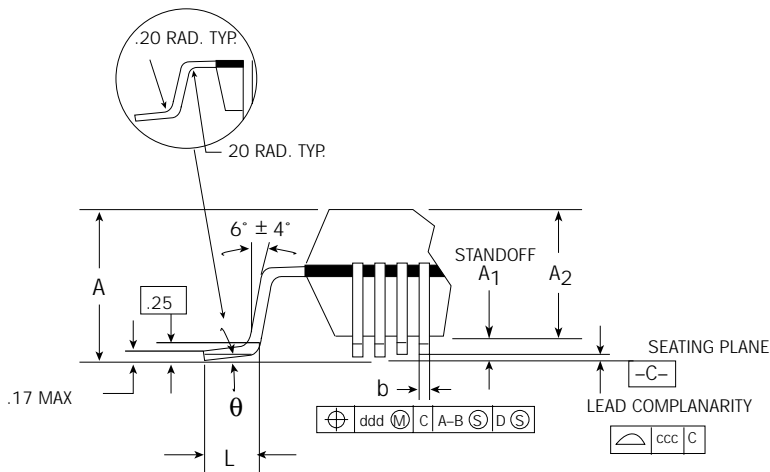

NOTES:

- 1) All dimensions in mm.
- 2) Dimensions shown are nominal with tol. as indicated.
- 3) L/F: EFTEC 64T copper or equivalent, 0.127 mm (.005") or 0.15 mm (.006") THICK.
- 4) Foot length "L" is measured at gage plane at 0.25 above the seating plane.

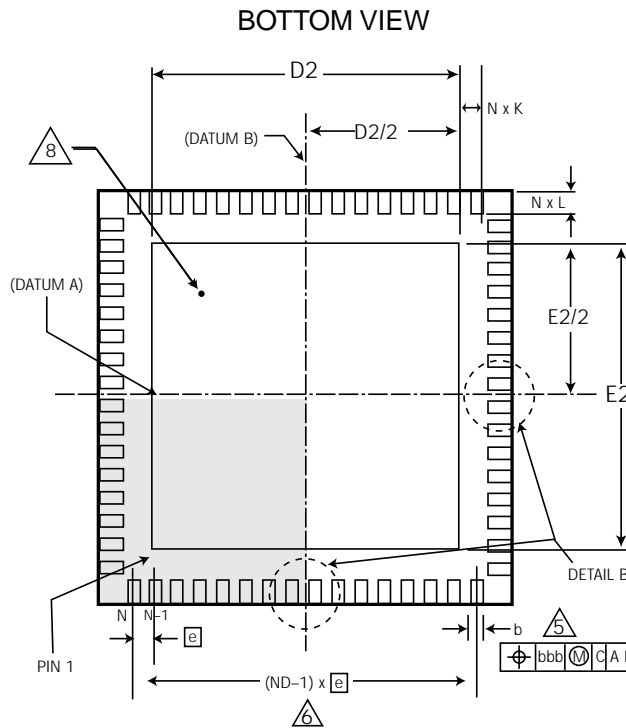
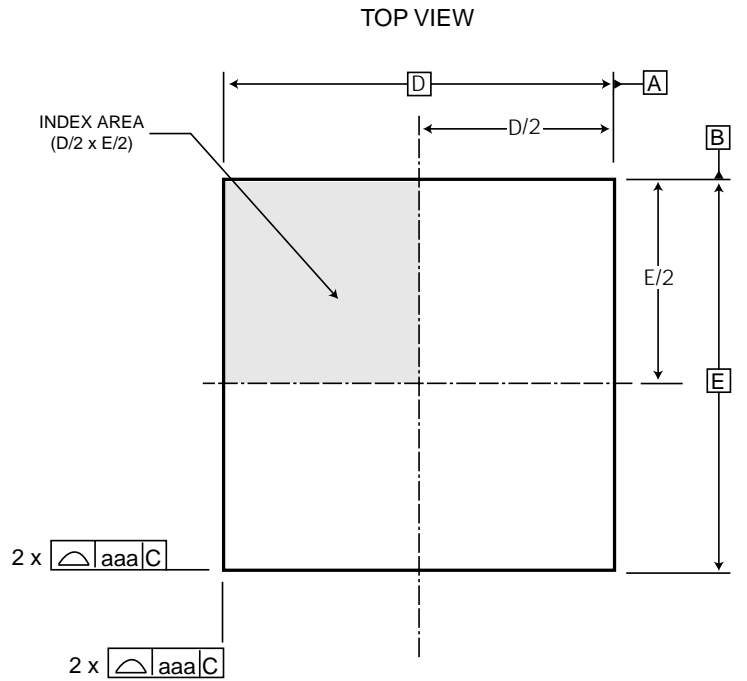
**64-Pad LPCC Package  
9mm x 9mm**

TEST AND MEASUREMENT PRODUCTS

E4237, E4257 Package Information (continued)

Detail B

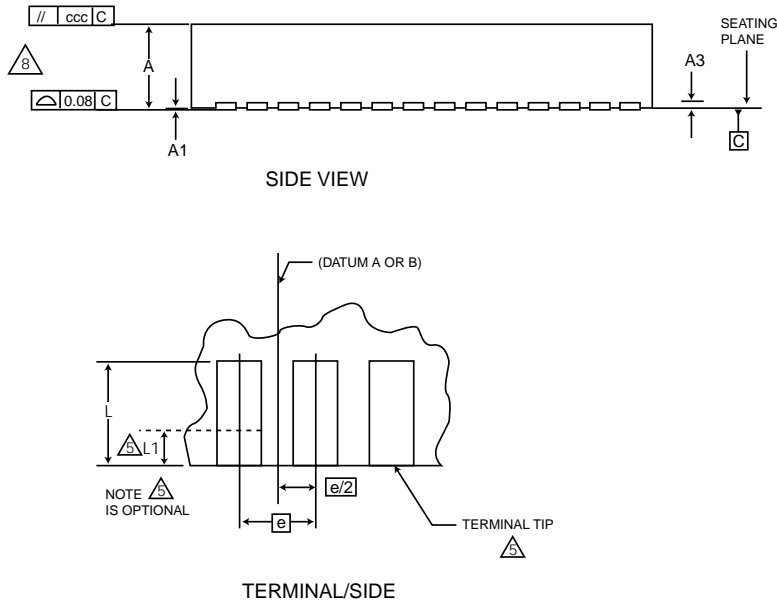

Ref.	MIN	NOM	MAX
A	0.80	0.90	1.00
A1	0	0.02	0.05
A3		0.20 Ref.	
b	0.18	0.25	0.30
D	8.90	9.00	9.10
D2	7.50	7.65	7.80
E	8.90	9.00	9.10
E2	7.50	7.65	7.80
e	0.50 BSC.		
k	0.20	-	-
x	b/2	-	-
L	0.35	0.40	0.45
N	64		
ND	16		
NE	16		
TOLERANCES OF FORM AND POSITION			
aaa		0.15	
bbb		0.10	
ccc		0.10	

NOTES:

- 1) Dimensioning and tolerancing conform to ASME Y14.5M-1994.
- 2) All dimensions are in millimeters. Angles are in degrees.
- 3) N is the total number of terminals.
- 4) The terminal #1 identifier and terminal numbering convention shall conform to JESD 95-1 SPP-012. Details of terminal #1 identifier are optional, but must be located within the zone indicated. The terminal #1 identifier may be either a mold or marked feature.
- 5) Dimension b applies to metallized terminal and is measured between 0.25mm and 0.30mm from terminal tip. Dimension L1 is the terminal pull back from package E up to 0.1mm is acceptable. L1 is optional.
- 6) ND and NE refer to the number of terminals on each D and E side respectively.
- 7) Depopulation is possible in a symmetrical fashion.
- 8) Bilateral coplanarity zone applies to exposed heat slug (if any) as well as the terminals.



**TEST AND MEASUREMENT PRODUCTS**
**Recommended Operating Conditions**

Parameter	Symbol	Min	Typ	Max	Units
Positive Analog Power Supply (relative to GND)	VCC	8	10	15	V
Negative Analog Power Supply (relative to GND)	VEE	-5.25	-5	-4.75	V
Total Analog Power Supply	(S)VCC – VEE	12.75	15	20.25	V
Positive Analog Switch Power Supply	SVCC	VCC		15	V
Digital Power Supply (relative to GND)	VDD	3.0	3.3	3.6	V
Junction Temperature	T <sub>j</sub>	25		85	°C
Thermal Resistance of Package (Junction to Case)	θ <sub>JC</sub>				
E4287 Junction to Top of Package			5		°C/W
E4237, E4257 Junction to Top of Package			12.7		°C/W
E4237 , E4257 Junction to Exposed Heat Slug (Bottom, Center)			0.4		°C/W

**Absolute Maximum Ratings**

Parameter	Symbol	Min	Typ	Max	Units
Positive Power Supply (relative to GND)	VCC, SVCC			16	V
Negative Power Supply (relative to GND)	VEE	-6.5			V
Total Power Supply	(S)VCC – VEE	-0.5		22.5	V
Digital Power Supply (relative to GND)	VDD	-0.5		4.5	V
Digital Inputs	DI	-0.5		VDD + 0.5	V
Analog Inputs	AI	VEE – .5		VCC + .5	V
Upper/Lower Voltage Limit Input to FORCE Pin Difference	HLV, LLV – VFORCE	0		17	V
Storage Temperature	TS	-55		+125	°C
Junction Temperature	TJ	-65		+125	°C
Soldering Temperature	TSOL			260	°C

Stresses above listed under “Absolute Maximum Ratings” may cause permanent damage to the device. This is a stress rating only and functional operation of the device at these or any other conditions above those “recommended” in the operational sections of this specification is not implied. Exposure to conditions above those “recommended” for extended periods may affect device reliability.

TEST AND MEASUREMENT PRODUCTS

DC Characteristics

Power Supplies

Parameter	Symbol	Min	Typ	Max	Units
Total Chip Power Supply Consumption (Quiescent, No-Load)					
Positive Supply Current (VCC)	ICC		10	25	mA
Negative Supply Current (VEE)	IEE	-25	-10		mA
Digital Supply Current (VDD)	IDD			3.5	mA
Positive Switch Supply Current (SVCC)	SICC			1	mA
Power Supply Rejection Ratio (see plot below for AC PSRR)					
FV/MI Mode	FV/MI PSRR				
FORCE Pin (DC)		70			dB
IVMON Pin (DC)		70			dB
FI/MV Mode	FI/MV PSRR				
FORCE Pin (DC)		70			dB
IVMON Pin (DC)		70			dB

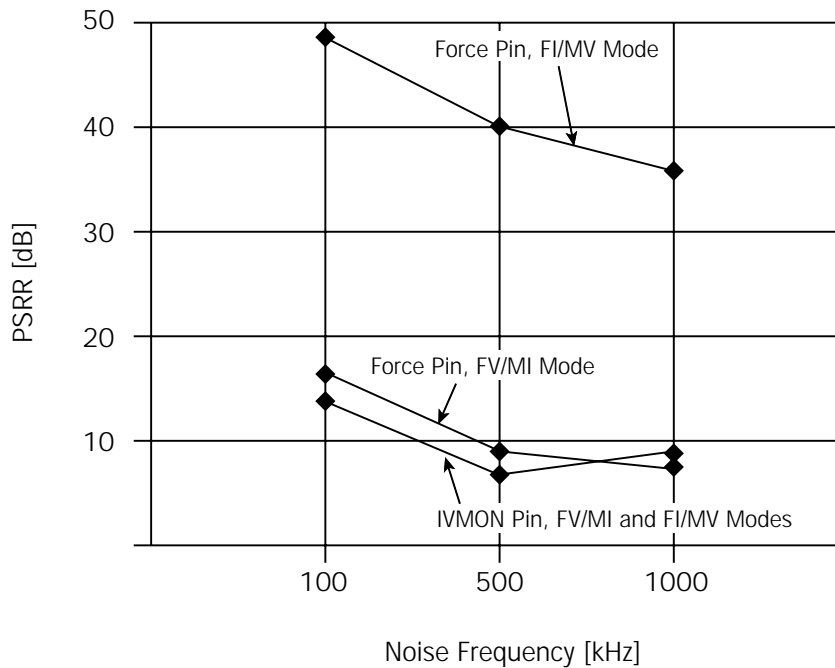

TEST AND MEASUREMENT PRODUCTS

DC Characteristics *(continued)*

Force Voltage

Parameter	Symbol	Min	Typ	Max	Units
Input Voltage Range @ VINP	VVINP	VEE + 1.75		VCC - 1.75	V
Input Leakage Current	IVINP	-200	0	+200	nA
Output Forcing Voltage					
RF Pin ( $\pm$ Full-Scale Current)	V <sub>RF</sub>	VEE + 2		VCC - 2	V
FORCE Pin (E4257, E4287)	V <sub>FORCE</sub>				
Ranges A, B, C ( $\pm$ Full-Scale Current)		VEE + 2		VCC - 2	V
Range D					
Sourcing Full-Scale Current		VEE + 2		VCC - 4	V
Zero Current		VEE + 2		VCC - 2	V
Sinking Full-Scale Current		VEE + 4		VCC - 2	V
FORCE Pin (E4237)					
Range A ( $\pm$ Full-Scale Current)		VEE + 2		VCC - 2	V
Range C					
Sourcing Full-Scale Current		VEE + 2		VCC - 4	V
Zero Current		VEE + 2		VCC - 2	V
Sinking Full-Scale Current		VEE + 4		VCC - 2	V
Force Amplifier Short Circuit Current Limit	I <sub>sc</sub> , I <sub>sk</sub>				
Range A		$\pm 0.5$		$\pm 1.6$	mA
Range B		$\pm 0.8$		$\pm 15$	mA
Range C		$\pm 9$		$\pm 45$	mA
Range D		$\pm 45$		$\pm 160$	mA
Voltage Accuracy					
Offset	V <sub>os</sub>	-50		50	mV
Gain	FV Gain	0.985		1.015	V/V
Linearity	FV INL	-0.01		+0.01	%FSVR
Temperature Dependence (Note 1)					
Temperature Coefficient of Offset	$\Delta V_{os}/\Delta T$		17		$\mu V/^{\circ}C$
Temperature Coefficient of Gain	$\Delta FV_{Gain}/\Delta T$		1		ppm/ $^{\circ}C$
Capacitive Loading Range at FORCE	C <sub>LOAD</sub>				
SELCOMP = 0		0		300	pF
SELCOMP = 1, CCOMP = 470 pF		0		10	nF

**TEST AND MEASUREMENT PRODUCTS**
**DC Characteristics (continued)**
**Measure Current**

Parameter	Symbol	Min	Typ	Max	Units
Current Measurement Range	IMEASURE				
Range A		-40		40	μA
Range B (E4257, E4287)		-400		400	μA
Range C		-4		4	mA
Range D (E4257, E4287)		-40		40	mA
Current Measurement Accuracy					
Measure Current Offset	VOS	-100		100	mV
Gain (Note 5)	MI Gain	3.91		4.15	V/V
Linearity	MI INL	-0.05		0.05	% FSCR
Common Mode Error (Note 2)	CM Error	-5.5		5.5	mV/V
Common Mode Linearity	ΔCM Error	-.05		0.05	%FSCR
Temperature Dependence (Note 1)					
Temperature Coefficient of Offset	ΔVos/ΔT		60		ppm/°C
Temperature Coefficient of Gain	ΔMI Gain/ΔT				
Ranges A, B, C			30		ppm/°C
Range D			360		ppm/°C

**TEST AND MEASUREMENT PRODUCTS**
**DC Characteristics (continued)**
**Force Current**

Parameter	Symbol	Min	Typ	Max	Units
Input Voltage Range @ VINP	VVINP	-2.5		2.5	V
Input Leakage Current	IIVIN	-200	0	+200	nA
Output Forcing Current	IFORCE				
Range A		-40		40	μA
Range B (E4257, E4287)		-400		400	μA
Range C		-4		4	mA
Range D (E4257, E4287)		-40		40	mA
Compliance Voltage Range					
RF Pin (± Full-Scale Current)	VRF	VEE + 2		VCC - 2	V
FORCE Pin (E4257, E4287)	VFORCE				
Ranges A, B, C (±Full-Scale Current)		VEE + 2		VCC - 2	V
Range D					
Sourcing Full-Scale Current		VEE + 2		VCC - 4	V
Zero Current		VEE + 2		VCC - 2	V
Sinking Full-Scale Current		VEE + 4		VCC - 2	V
FORCE Pin (E4237)		VEE + 2		VCC - 2	V
Range A (±Full-Scale Current)					
Range C					
Sourcing Full-Scale Current		VEE + 2		VCC - 4	V
Zero Current		VEE + 2		VCC - 2	V
Sinking Full-Scale Current		VEE + 4		VCC - 2	V
Current Accuracy					
Offset	Ios	-5		5	% FSR
Gain (Note 4)	FI Gain				
Ranges A, B, C		0.241		0.256	V/V
Range D		0.234		0.256	V/V
Linearity	FI INL				
Range A		-0.07		0.05	%FSCR
Ranges B, C, D (Spec at ±0.05% FSCR)		-0.05		0.05	%FSCR
Common Mode Error	CM Error	-0.15		0.15	%FSCR/V
Common Mode Linearity	ΔCM Error	-.05		0.05	%FSCR
Temperature Dependence (Note 1)					
Temperature Coefficient of Offset	ΔIos/ΔT		15		ppm/°C
Temperature Coefficient of Gain	ΔFI Gain/ΔT				
Ranges A, B, C			2		ppm/°C
Range D			20		ppm/°C
Capacitive Loading Range at FORCE	CLOAD				
SELCOMP = 0		0		300	pF
SELCOMP = 1, CCOMP = 470 pF		0		10	nF

**TEST AND MEASUREMENT PRODUCTS**
**DC Characteristics (continued)**
**Measure Voltage**

Parameter	Symbol	Min	Typ	Max	Units
Voltage Measurement Range	VSENSE	VEE + 2		VCC - 2	V
Voltage Measurement Accuracy					
Measure Voltage Offset	Vos	-50		50	mV
Gain	MV Gain	.985		1.015	V/V
Linearity	MV INL	-0.01		+0.01	%FSVR
Temperature Dependence (Note 1)					
Temperature Coefficient of Offset	$\Delta V_{os}/\Delta T$		10		$\mu V/^{\circ}C$
Temperature Coefficient of Gain	$\Delta MV \text{ Gain}/\Delta T$		1		ppm/ $^{\circ}C$

**Digital Inputs (FV/FI, MI/MV, RS0, RS1, SELIPMU, SELEPMU, SELC, SELCOMP, HiZ, DISMON)**

Parameter	Symbol	Min	Typ	Max	Units
Input Low Level	VIL			0.8	V
Input High Level	VIH	2.4			V
Input Leakage Current	IIN	-200		+200	nA

TEST AND MEASUREMENT PRODUCTS

DC Characteristics *(continued)*

Force & Sense Switches

Parameter	Symbol	Min	Typ	Max	Units
Internal Force Switches					
On-Resistance E4257, E4287 E4237	RONRF_FORCE		40 400	50 500	$\Omega$
External Force Switches					
Usable Input Voltage Range @ EPMUF	VEPMUF	VEE		SVCC	V
Usable Input Current Range @ EPMUF	IEPMUF	-40		40	mA
On-resistance	RONPEMUF		40	50	$\Omega$
Leakage Current @ EPMUF				10	
Switch Open (SELEPMU = 0)	Ileak	-10		10	nA
Switch Closed (SELEPMU = 1)	Ileak	-10			nA
Input Capacitance SELEPMU = 1)	EPMUF		120		pF
External Sense Switches					
Usable Input Voltage Range @ EPMUS	VEPMUS	VEE		SVCC	V
Usable Input Current Range @ EPMUS	IEPMUS	-4		4	mA
On-resistance	RONPEMUS		1	1.8	k $\Omega$
Leakage Current					
Switch Open (SELEPMU = 0)	Ileak	-10		10	nA
Switch Closed (SELEPMU = 1)	Ileak	-10		10	nA
HiZ (Switches Open) Leakage Current (Note 3)	Ileak				
@ FORCE = VEE + 2V to VCC - 2V		-10		10	nA
@ RF = VEE + 2V to VCC - 2V		-10		10	nA
@ SENSE = VEE + 2V to VCC - 2V		-10		10	nA
FORCE Pin Capacitance (Note 3)	CFORCE				
SELIPMU = SELEPMU = 0 (E4257, E4287)		0	35	110	pF
SELIPMU = SELEPMU = 0 (E4237)		0	13	20	pF
SELIPMU = 1, SELEPMU = 0 (E4257, E4287)		0		110	pF
SELIPMU = 1, SELEPMU = 0 (E4237)		0		110	pF
SENSE Pin Capacitance (Note 3)	CSENSE	0		3	pF
Internal Pull-Up Current Capability	IRPU	-6		6	mA
Internal Pull-Up Resistance (Switch & Resistor)	RPU	2.5	4.5	6	k $\Omega$

**TEST AND MEASUREMENT PRODUCTS**
**DC Characteristics (continued)**
**Voltage Clamp**

Parameter	Symbol	Min	Typ	Max	Units
Upper Voltage Limit Input Range	HLV	LLV + 1.0		VCC - 1.675	V
Lower Voltage Limit Input Range (Note 6)	LLV	VEE + 1.675		VCC - 6	V
Upper/Lower Voltage Limit Input to FORCE	HLV, LLV - VFORCE	0		16.5	V
Pin Difference					
Upper/Lower Voltage Limit Input Current	IHLV, ILLV	-200		+200	nA
Voltage Limiting Accuracy					
Upper Voltage Limit (HLV)	VLIMIT+	HLV - 0.325		HLV + 0.325	V
Lower Voltage Limit (LLV)	VLIMIT-	LLV - 0.325		LLV + 0.325	V
Voltage clamp Current Limiting	ICLAMP	42		150	mA
FORCE Pin Short Circuit Protection Threshold	Vprotect				
HLV		HLV + 0.5		HLV + 2.5	V
LLV		LLV - 2.5		LLV - 0.5	V

**Analog MUX (E4287 ONLY)**

Parameter	Symbol	Min	Typ	Max	Units
Usable Input Voltage Range (VA, VB, VC)	Vin	VEE		SVCC	V
MUX "Super Voltage" Input Channel 0 to Channel 1 Difference	VVC[0] - VVC[1]	-1.5		SVCC	V
Switch On-Resistance @ 500 $\mu$ A	RON_MUX		1300	2000	$\Omega$
On-Resistance Variability (Across full VEE to SVCC Range)	$\Delta$ RON_MUX			500	$\Omega$
Leakage Current	ILEAK_MUX			100	nA

**IVMON**

Parameter	Symbol	Min	Typ	Max	Units
Leakage (both IVMON switches open)	ILEAK_IVMON	-20		+20	nA
IVMON Output Switch Impedance	RIVMONSW	0.3		1.2	k $\Omega$
IVMON Output Current Capability	IIVMON	-4		4	mA
IVMON Output Capacitance (both IVMON switches open)	CIVMON	0		5	pF



TEST AND MEASUREMENT PRODUCTS

DC Characteristics (continued)

Comparator

Parameter	Symbol	Min	Typ	Max	Units
IVMAX Voltage Range	IVMAX	VEE + 1.75		VCC - 1.75	V
IVMIN Voltage Range	IVMIN	VEE + 1.75		VCC - 1.75	V
Comparator Offset (IVMIN, IVMAX)	Vos	-100		+100	mV
Input Bias Current at IVMIN, IVMAX	Ibias	-200		+200	nA

DUTNL, DUTNH

Parameter	Symbol	Min	Typ	Max	Units
Output Low Level (DUTNH (L)) @  IOL  = 1.6 mA	VOL			400	mV
Output High Level (DUTNH (L)) @  IOH  = 400 μA	VOH	2.4			V

Test Head Remote Ground

Parameter	Symbol	Min	Typ	Max	Units
DUTGND Voltage Range (referenced to GND)	DUTGND	-250		250	mV
DUTGND Leakage Current	Ileak	-200		+200	nA

Driven Guard (E4287 ONLY)

Parameter	Symbol	Min	Typ	Max	Units
GUARD - SENSE @ DUTGND = 0V, VSENSE = 5V	VDIFF	-100		100	mV

DC Characteristic specifications are guaranteed over full Recommended Operating Condition ranges unless otherwise noted.

Note 1: Temperature coefficients are valid over a 25 °C to 85 °C junction temperature range unless otherwise noted.

Note 2: The mV/V units shown are derived as follows: (Δoffset current \* range resistance) / Δoutput force voltage.

Note 3: SELIPMU = SELEPMU = FV/FI = 0.

Note 4: FI Gain =  $\frac{\Delta I_{FORCE} \times R_{EXT}}{\Delta V_{INP}}$

Note 5: MI Gain =  $\frac{\Delta V_{IVMON}}{\Delta I_{FORCE} \times R_{EXT}}$

Note 6: VCC - 6V is the maximum LLV voltage that will clamp full-scale current on Range D. LLV will clamp full-scale current for ranges A, B, and C all the way up to HLV - 1V.

Unit Definitions:
FSVR = Full-Scale Voltage Range
FORCE Pin: FSVR = 16.25V (max supplies) @ Zero Current FSVR = 12.25V (max supplies) @ Full-Scale Current
RF Pin: FSVR = 16.25V (max supplies) Across Entire Current Range
FSCSR = Full-Scale Current Range
Range A: 80 μA Range B: 800 μA Range C: 8 mA Range D: 80 mA

**TEST AND MEASUREMENT PRODUCTS**
**AC Characteristics**
**Force Voltage/Measure Current**

Parameter	Symbol	Min	Typ	Max	Units
Force Output Voltage Settling Time (Note 2) CFORCE/SENSE = 100 pF, SELCOMP = 0 To $\pm 0.025\%$ FSVR Range A Range B (E4257, E4287) Range C Range D (E4257, E4287)  To $\pm 0.1\%$ FSVR Range A Range B (E4257, E4287) Range C Range D (E4257, E4287)  CFORCE/SENSE = 1,000 pF, SELCOMP = 1, CCOMP = 470 pF To $\pm 0.025\%$ FSVR Range A Range B (E4257, E4287) Range C Range D (E4257, E4287)  To $\pm 0.1\%$ FSVR Range A Range B (E4257, E4287) Range C Range D (E4257, E4287)	FVtsettle				
			25	105	$\mu\text{s}$
			25	95	$\mu\text{s}$
			25	85	$\mu\text{s}$
			15	75	$\mu\text{s}$
			17	95	$\mu\text{s}$
			17	85	$\mu\text{s}$
			17	75	$\mu\text{s}$
			10	65	$\mu\text{s}$
			115	200	$\mu\text{s}$
			35	120	$\mu\text{s}$
			30	110	$\mu\text{s}$
			30	100	$\mu\text{s}$
			75	130	$\mu\text{s}$
			25	110	$\mu\text{s}$
			20	100	$\mu\text{s}$
			20	90	$\mu\text{s}$
Measure Current Settling Time (Note 4) CFORCE/SENSE = 100 pF, SELCOMP = 0 To $\pm 0.05\%$ FSCR Range A Range B (E4257, E4287) Range C Range D (E4257, E4287)  To $\pm 0.1\%$ FSCR Range A Range B (E4257, E4287) Range C Range D (E4257, E4287)  CFORCE/SENSE = 1,000 pF, SELCOMP = 1, CCOMP = 470 pF To $\pm 0.05\%$ FSCR Range A Range B (E4257, E4287) Range C Range D (E4257, E4287)  To $\pm 0.1\%$ FSCR Range A Range B (E4257, E4287) Range C Range D (E4257, E4287)	Mltsettle				
			105	550	$\mu\text{s}$
			40	195	$\mu\text{s}$
			30	150	$\mu\text{s}$
			40	100	$\mu\text{s}$
			75	200	$\mu\text{s}$
			35	125	$\mu\text{s}$
			25	100	$\mu\text{s}$
			30	75	$\mu\text{s}$
			230	420	$\mu\text{s}$
			50	200	$\mu\text{s}$
			40	175	$\mu\text{s}$
			45	150	$\mu\text{s}$
			200	270	$\mu\text{s}$
			40	150	$\mu\text{s}$
			30	125	$\mu\text{s}$
			40	100	$\mu\text{s}$

**TEST AND MEASUREMENT PRODUCTS**
**AC Characteristics (continued)**
**Force Voltage/Measure Current (continued)**

Parameter	Symbol	Min	Typ	Max	Units
Force Amplifier Slew Rate	SR	0.9	1		V/ $\mu$ s
I/V Monitor (Note 3)					
DISABLE True to VMON Disable Time	tz			750	ns
DISABLE False to IVMON Enable Time	toe			1.5	$\mu$ s
Slew Rate	$\Delta V/\Delta t$	5		6.7	V/ $\mu$ s
Voltage Clamp					
Activation Time (Note 5)	tA			6	$\mu$ s
Recovery Time (Note 5)	tR			6	$\mu$ s
Overshoot	Vovershoot			0.5	V
Force Amp					
HiZ True to FORCE Disable Time (Note 3)	tz			10	$\mu$ s
HiZ False to FORCE Enable Time (Note 3)	toe			45	$\mu$ s

TEST AND MEASUREMENT PRODUCTS

AC Characteristics (continued)

Force Current/Measure Voltage

Parameter	Symbol	Min	Typ	Max	Units
Force Output Current Settling Time (Note 2) CFORCE/SENSE = 100 pF, SELCOMP = 0 To ±0.05% FSCR Range A Range B (E4257, E4287) Range C Range D (E4257, E4287)  To ±0.1% FSCR Range A Range B (E4257, E4287) Range C Range D (E4257, E4287)  CFORCE/SENSE = 1,000 pF, SELCOMP = 1, CCOMP = 470 pF To ±0.05% FSCR Range A Range B (E4257, E4287) Range C Range D (E4257, E4287)  To ±0.1% FSCR Range A Range B (E4257, E4287) Range C Range D (E4257, E4287)	Fitsettle				
			320	575	µs
			45	185	µs
			30	135	µs
			30	85	µs
			270	450	µs
			35	175	µs
			25	125	µs
			20	75	µs
			540	700	µs
			70	250	µs
			30	200	µs
			40	150	µs
			490	650	µs
			60	200	µs
			25	150	µs
			30	95	µs
Measure Voltage Settling Time (Note 4) CFORCE/SENSE = 100 pF, SELCOMP = 0 To ±0.025% FSVR Range A Range B (E4257, E4287) Range C Range D (E4257, E4287) To ±0.1% FSVR Range A Range B (E4257, E4287) Range C Range D (E4257, E4287)  CFORCE/SENSE = 1,000 pF, SELCOMP = 1, CCOMP = 470 pF To ±0.025% FSVR Range A Range B (E4257, E4287) Range C Range D (E4257, E4287)  To ±0.1% FSVR Range A Range B (E4257, E4287) Range C Range D (E4257, E4287)	MVtsettle				
			270	425	µs
			40	175	µs
			22	70	µs
			20	60	µs
			205	350	µs
			25	100	µs
			15	60	µs
			10	50	µs
			490	620	µs
			60	195	µs
			25	80	µs
			30	70	µs
			400	510	µs
			45	175	µs
			15	70	µs
			20	60	µs

**TEST AND MEASUREMENT PRODUCTS**

**AC Characteristics (continued)**

**Force Current/Measure Voltage (continued)**

Parameter	Symbol	Min	Typ	Max	Units
Force Amplifier Slew Rate	SR	0.9	1		V/μs
I/V Monitor (Note 3)					
DISABLE True to VMON Disable Time	tz			750	ns
DISABLE False to IVMON Enable Time	toe			1.5	μs
Slew Rate	ΔV/Δt	5		6.7	V/μs
Voltage Clamp					
Activation Time (Note 5)	tA			6	μs
Recovery Time (Note 5)	tR			6	μs
Overshoot	Vovershoot			0.5	V
Force Amp					
HiZ True to FORCE Disable Time (Note 3)	tz			10	μs
HiZ False to FORCE Enable Time (Note 3)	toe			45	μs

**Comparator**

Parameter	Symbol	Min	Typ	Max	Units
Propagation Delay (Note 6)	tpd(+), (-)				
> 3V Swing					
Minimum Pulse Width				2	μs
(3V swing, IVMAX/IVMIN set to 50%)					
Maximum Toggle Rate				166	kHz

**TEST AND MEASUREMENT PRODUCTS**

**AC Characteristics (continued)**

- Note 1: Settling times are not production tested. Guaranteed by characterization.
- Note 2: Measured from full-scale step at VINP to FORCE output.
- Note 3: Test Conditions:
  1. 15 pF load on output
  2. input signal has 5 ns rise/fall time
  3. tpd is defined as the difference between the time when the input crosses 1.5V to when the output changes 10% (of the total change) from the initial voltage level. (see timing diagram below).

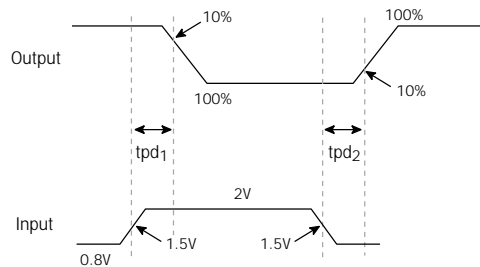

- Note 4: Measured from full-scale step at VINP to IVMON output.
- Note 5: Clamp activation/recovery time indicates the delay between when the clamps are actually engaged or disengaged and when clamping is indicated with the comparator outputs.
- Note 6: Comparator Propagation Delay Measurements.  
 HiZ = 1, MI/MV\* = 0, SELIPMU = 1, input signal applied to FORCE/SENSE.

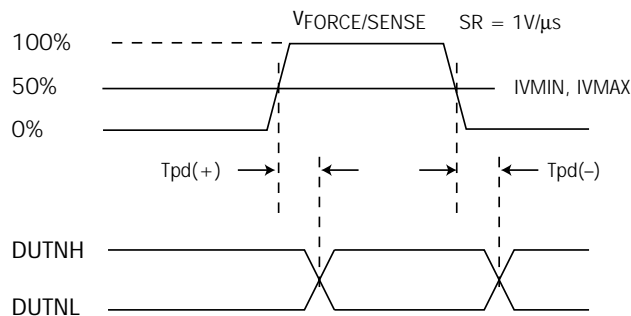

<b>Unit Definitions:</b>
FSVR = Full-Scale Voltage Range
FORCE Pin: FSVR = 16.25V (max supplies) @ Zero Current FSVR = 12.25V (max supplies) @ Full-Scale Current
RF Pin: FSVR = 16.25V (max supplies) Across Entire Current Range
FSCR = Full-Scale Current Range
Range A: 80 μA
Range B: 800 μA
Range C: 8 mA
Range D: 80 mA

TEST AND MEASUREMENT PRODUCTS

Ordering Information

Model Number	Package
E4287AHFT	14 x 14 x 2.0 mm, 80 Pin, Int_TEP_MQFP (with Internal Heat Spreader)
EVM4287AHFT	Edge4287 Evaluation Module

Model Number	Package
E4237ALPT	9mm x 9mm, 64-Pad, LPCC
E4237ALPT-T	9mm x 9mm 64-Pad, LPCC (Tape & Reel)
EVM4237ALPT	Edge4237 Evaluation Module

Model Number	Package
E4257ALPT	9mm x 9mm, 64-Pad, LPCC
E4257ALPT-T	9mm x 9mm 64-Pad, LPCC (Tape & Reel)
EVM4257ALPT	Edge4257 Evaluation Module

 This product is lead-free.

Contact Information

Semtech Corporation  
 Test and Measurement Division  
 10021 Willow Creek Rd., San Diego, CA 92131  
 Phone: (858)695-1808 FAX (858)695-2633