

Fast Diode Full Bridge Power Module

$V_{RRM} = 600V$
 $I_C = 30A @ T_c = 90^{\circ}C$

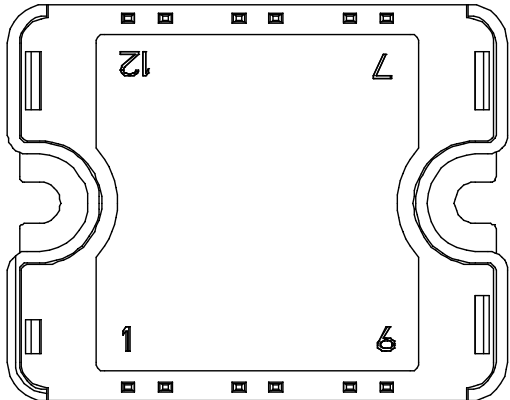
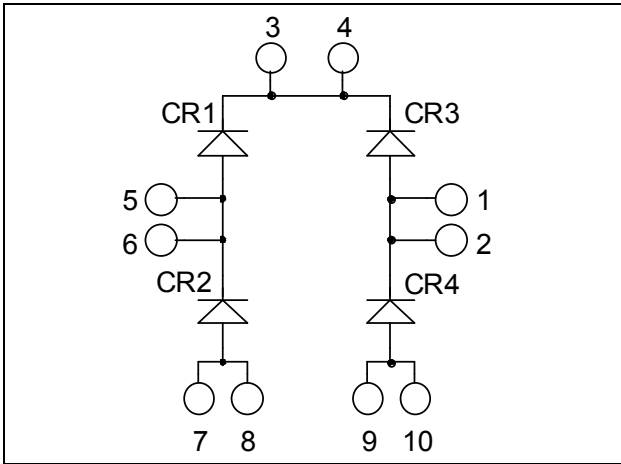

All multiple inputs and outputs must be shorted together
 3/4 ; 5/6 ; 7/8 ; 1/2 ; 9/10

Application

- Uninterruptible Power Supply (UPS)
- Induction heating
- Welding equipment
- High speed rectifiers

Features

- Ultra fast recovery times
- Soft recovery characteristics
- High blocking voltage
- High current
- Low leakage current
- Very low stray inductance
- High level of integration

Benefits

- Outstanding performance at high frequency operation
- Low losses
- Low noise switching
- Solderable terminals for easy PCB mounting
- Direct mounting to heatsink (isolated package)
- Low junction to case thermal resistance
- RoHS Compliant

Absolute maximum ratings

| Symbol | Parameter | Max ratings | Unit |
|-------------|---|---------------------|------|
| V_R | Maximum DC reverse Voltage | 600 | V |
| V_{RRM} | Maximum Peak Repetitive Reverse Voltage | | |
| $I_{F(AV)}$ | Maximum Average Forward Current | Duty cycle = 50% | 42 |
| | | $T_C = 25^{\circ}C$ | 30 |
| I_{FSM} | Non-Repetitive Forward Surge Current | 8.3ms | 250 |
| | | $T_J = 45^{\circ}C$ | A |

CAUTION: These Devices are sensitive to Electrostatic Discharge. Proper Handling Procedures Should Be Followed. See application note APT0502 on www.microsemi.com

All ratings @ $T_j = 25^\circ\text{C}$ unless otherwise specified

Electrical Characteristics

| Symbol | Characteristic | Test Conditions | Min | Typ | Max | Unit |
|----------|---------------------------------|---------------------|---------------------------|-----|-----|---------------|
| V_F | Diode Forward Voltage | $I_F = 30\text{A}$ | | 1.8 | 2.2 | V |
| | | $I_F = 60\text{A}$ | | 2.2 | | |
| | | $I_F = 30\text{A}$ | $T_j = 125^\circ\text{C}$ | 1.5 | | |
| I_{RM} | Maximum Reverse Leakage Current | $V_R = 600\text{V}$ | $T_j = 25^\circ\text{C}$ | | 250 | μA |
| | | | $T_j = 125^\circ\text{C}$ | | 500 | |
| C_T | Junction Capacitance | $V_R = 200\text{V}$ | | 36 | | pF |

Dynamic Characteristics

| Symbol | Characteristic | Test Conditions | Min | Typ | Max | Unit |
|-----------|--------------------------|---|---------------------------|-----|-----|------|
| t_{rr} | Reverse Recovery Time | $I_F = 30\text{A}$ $V_R = 400\text{V}$ $di/dt = 200\text{A}/\mu\text{s}$ | $T_j = 25^\circ\text{C}$ | | 25 | ns |
| | | | $T_j = 125^\circ\text{C}$ | | 160 | |
| Q_{rr} | Reverse Recovery Charge | | $T_j = 25^\circ\text{C}$ | | 35 | nC |
| | | | $T_j = 125^\circ\text{C}$ | | 480 | |
| I_{RRM} | Reverse Recovery Current | | $T_j = 25^\circ\text{C}$ | | 3 | A |
| | | | $T_j = 125^\circ\text{C}$ | | 6 | |
| t_{rr} | Reverse Recovery Time | $I_F = 30\text{A}$ $V_R = 400\text{V}$ $di/dt = 1000\text{A}/\mu\text{s}$ | $T_j = 125^\circ\text{C}$ | | 85 | ns |
| Q_{rr} | Reverse Recovery Charge | | | | 920 | nC |
| I_{RRM} | Reverse Recovery Current | | | | 20 | A |

Thermal and package characteristics

| Symbol | Characteristic | Min | Typ | Max | Unit | |
|------------|--|-------------|-----|-----|---------------------------|-----|
| R_{thJC} | Junction to Case Thermal Resistance | | | 1.2 | $^\circ\text{C}/\text{W}$ | |
| V_{ISOL} | RMS Isolation Voltage, any terminal to case $t = 1\text{ min}$, $I_{isol} < 1\text{mA}$, 50/60Hz | 2500 | | | V | |
| T_j | Operating junction temperature range | -40 | | 175 | $^\circ\text{C}$ | |
| T_{STG} | Storage Temperature Range | -40 | | 125 | | |
| T_C | Operating Case Temperature | -40 | | 100 | | |
| Torque | Mounting torque | To heatsink | M4 | 2.5 | 4.7 | N.m |
| Wt | Package Weight | | | | 80 | g |

Typical Performance Curve

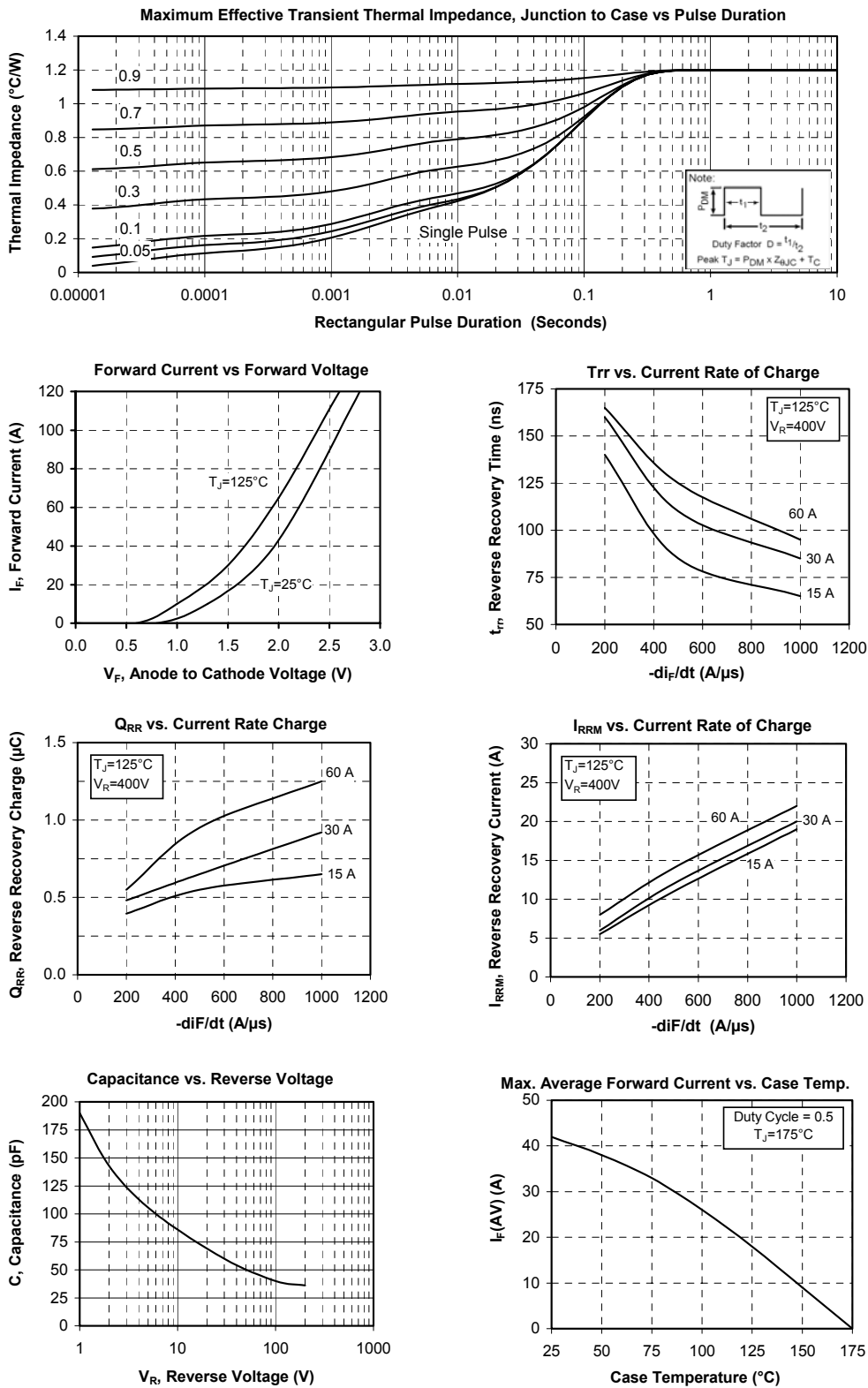

SP1 Package outline (dimensions in mm)

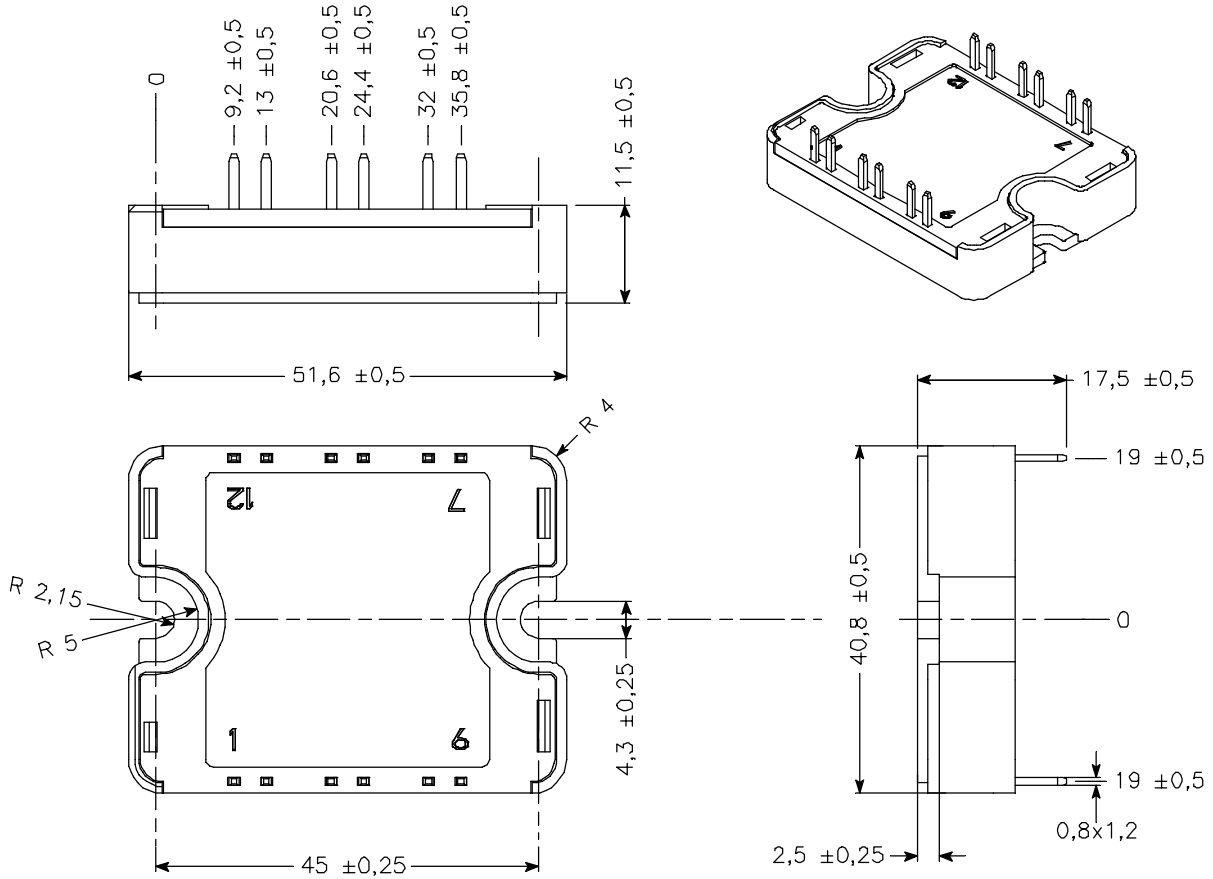

See application note 1904 - Mounting Instructions for SP1 Power Modules on www.microsemi.com

Microsemi reserves the right to change, without notice, the specifications and information contained herein

Microsemi's products are covered by one or more of U.S. patents 4,895,810 5,045,903 5,089,434 5,182,234 5,019,522 5,262,336 6,503,786 5,256,583 4,748,103 5,283,202 5,231,474 5,434,095 5,528,058 and foreign patents. U.S. and Foreign patents pending. All Rights Reserved.