

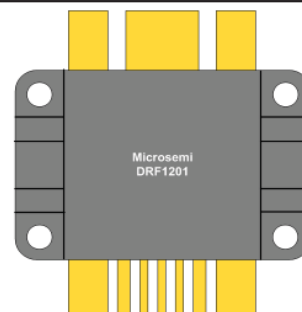

MOSFET Driver Hybrid

The DRF1201 hybrid includes a high power gate driver and the power MOSFET. The driver output can be configured as Inverting and Non-Inverting. It was designed to provide the system designer increased flexibility and lowered cost over a non-integrated solution.

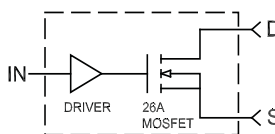

FEATURES

- Switching Frequency: DC TO 30MHz
- Low Pulse Width Distortion
- Single Power Supply
- 1V CMOS Schmitt Trigger Input 1V Hysteresis
- Inverting Non-Inverting Select
- RoHS Compliant 
- Switching Speed 3-4ns
- $B_{V_{ds}} = 1Kv$
- $I_{ds} = 26A$ avg.
- $R_{ds(on)} \leq .55$ Ohm
- $P_D = 1100W$

TYPICAL APPLICATIONS

- Class C, D and E RF Generators
- Switch Mode Power Amplifiers
- Pulse Generators
- Ultrasound Transducer Drivers
- Acoustic Optical Modulators

Driver Absolute Maximum Ratings

Symbol	Parameter	Ratings	Unit
V_{DD}	Supply Voltage	18	V
IN, FN	Input Single Voltages	-.7 to +5.5	
$I_{O_{PK}}$	Output Current Peak	8	A
T_{JMAX}	Operating Temperature	175	°C

Driver Specifications

Symbol	Parameter	Min	Typ	Max	Unit
V_{DD}	Supply Voltage	8	15	18	V
IN	Input Voltage	3		5.5	
$IN_{(R)}$	Input Voltage Rising Edge		3		ns
$IN_{(F)}$	Input Voltage Falling Edge		3		
I_{DDQ}	Quiescent Current		2		mA
I_O	Output Current		8		A
C_{OSS}	Output Capacitance		2500		pF
C_{ISS}	Input Capacitance		3		
R_{IN}	Input Parallel Resistance		1		mΩ
$V_{T(ON)}$	Input, Low to High Out	0.8		1.1	V
$V_{T(OFF)}$	Input, High to Low Out	1.9		2.2	
T_{DLY}	Time Delay (throughput)		38		ns
t_r	Rise Time		5		ns
t_f	Fall Time		5		
T_D	Prop. Delay		35		

Symbol	Parameter	Min	Typ	Max	Unit
BV_{DSS}	Drain Source Voltage	1000			V
I_D	Continuous Drain Current $T_{HS} = 25^\circ\text{C}$			26	A
$R_{DS(on)}$	Drain-Source On State Resistance		0.55		Ω

Dynamic Characteristics

Symbol	Parameter	Min	Typ	Max	Unit
C_{iss}	Input Capacitance		2000		pF
C_{oss}	Output Capacitance		165		
C_{rss}	Reverse Transfer Capacitance		75		

Thermal Characteristics

Symbol	Parameter	Min	Typ	Max	Unit
$R_{\theta JC}$	Thermal Resistance Junction to Case		0.09		$^\circ\text{C}/\text{W}$
$R_{\theta JHS}$	Thermal Resistance Junction to Heat Sink		0.24		
T_{JSTG}	Storage Temperature		-55 to 150		$^\circ\text{C}$
P_D	Maximum Power Dissipation @ $T_{SINK} = 25^\circ\text{C}$		1100		W
P_{DC}	Total Power Dissipation @ $T_C = 25^\circ\text{C}$		2900		

Microsemi reserves the right to change, without notice, the specifications and information contained herein.

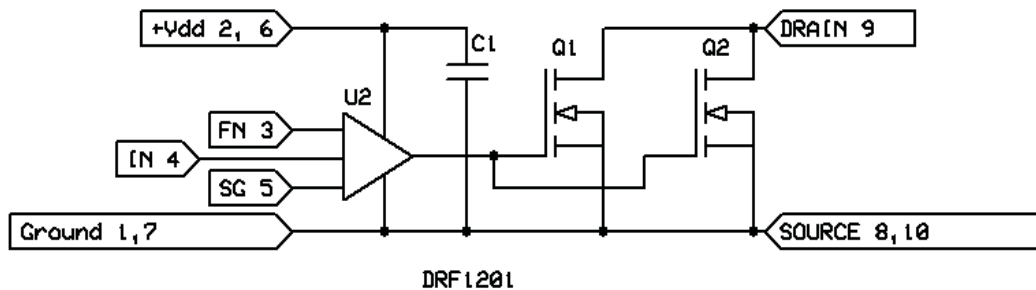

Figure 1, DRF1201 Simplified Circuit Diagram

The Simplified DRF1201 Circuit Diagram is illustrated above. By including the driver high speed by-pass capacitor (C1), the contribution to the internal parasitic loop inductance of the driver output is greatly reduced. This, coupled with the tight geometry of the hybrid, allows optimal gate drive to the MOSFET. This low parasitic approach, coupled with the Schmitt trigger input (IN), Kelvin signal ground (SG) and the Anti-Ring Function, provide improved stability and control in Kilowatt to Multi-Kilowatt, high Frequency applications. Both the FN and IN pins are referenced to the Kelvin ground (SG.) The signal is then applied to the intermediate drivers and level shifters; this section contains proprietary circuitry designed specifically for the ring abatement. The power drivers provide high current to the gate of the MOSFETS.

The Function (FN, pin 3) is the invert or non-invert select Pin, it is Internally held high, Normally Non-inverting.

Truth Table *Referenced to SG			
FN (pin 3)*	IN (pin 4)*	MOSFET	Function
HIGH	HIGH	ON	Non-Invert
HIGH	LOW	OFF	Non-Invert
LOW	HIGH	OFF	Inverting
LOW	LOW	ON	Inverting

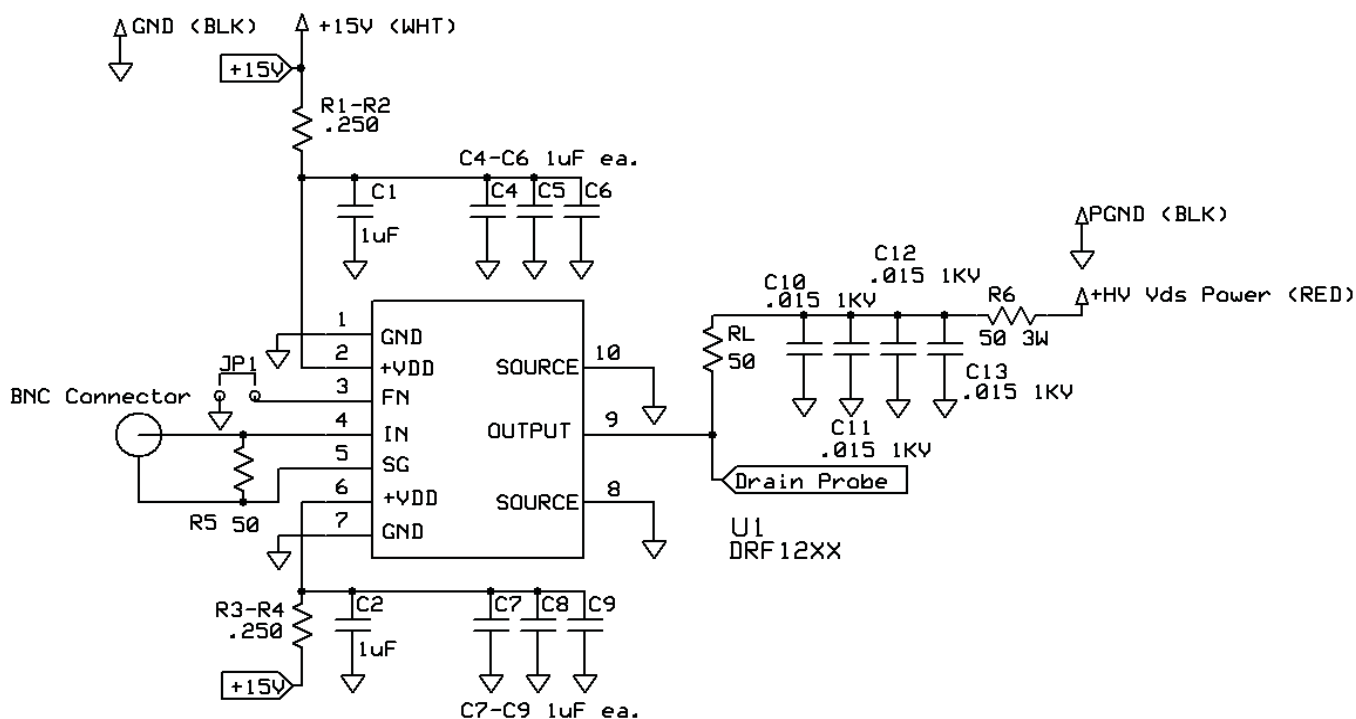
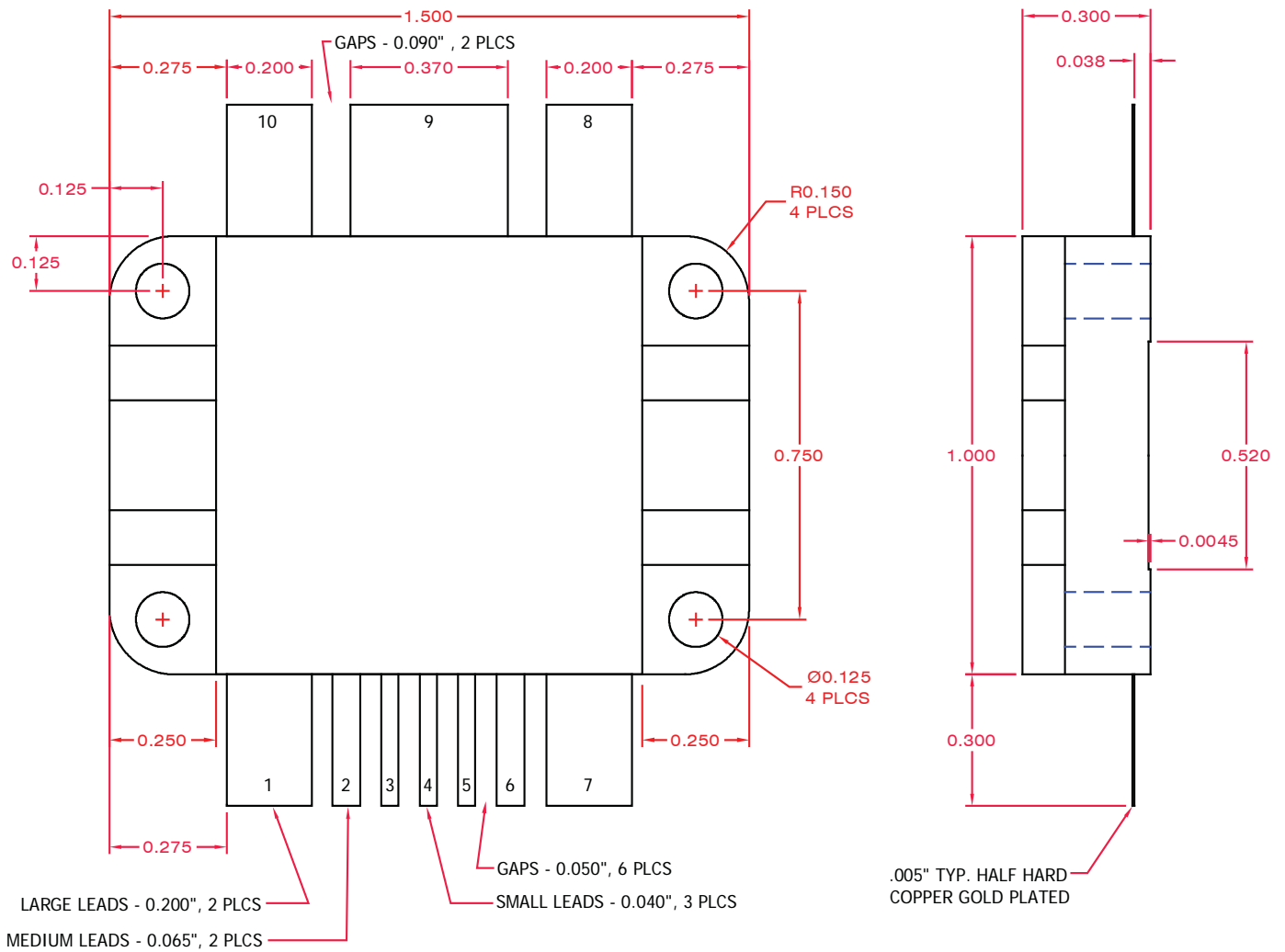

Figure 2, DRF1201 Test Circuit

The Test Circuit illustrated above was used to evaluate the DRF1201 (available as an evaluation Board DRF12XX / EVALSW.) The input control signal is applied to the DRF1201 via IN(4) and SG(5) pins using RG188. This provides excellent noise immunity and control of the signal ground currents.

The $+V_{DD}$ inputs (2,6) are by-passed (C1, C2, C4-C9), this is in addition to the internal by-passing mentioned previously. The capacitors used for this function must be capable of supporting the RMS currents and frequency of the gate load. A 50 Ω (RL) load is used to evaluate the output performance of the DRF1201.

Pin Assignments	
Pin 1	Ground
Pin 2	U1 +Vdd
Pin 3	FN
Pin 4	U1 IN
Pin 5	U1 SG
Pin 6	U1 +Vdd
Pin 7	Ground
Pin 8	Source
Pin 9	Drain
Pin 10	Source



All dimensions are ± .005

Figure 3, DRF1201 Mechanical Outline