



Hi-Rel AC/DC PFC MODULE HGMM-35 : 35W POWER

Hi-Rel Grade ■■

**115 VAC/400Hz Active Power Factor Corrected
Variable Frequency 360-800Hz
Dual Isolated Output
Metallic Case**

- AC/DC Isolated Power Factor Corrected Module
 - 115 VAC single phase
 - Input range : 95 - 140 VAC
 - Variable frequency : 360 - 800 Hz
 - MIL-STD-704, ABD100 compliant
- Low input current harmonic distortion < 10%
- Output Power : 35W
- Active inrush current limitation
- Isolation : 1.500 Vrms
- Inhibition function
- RoHS or Leaded process option



1- General

The GAIA Converter HGMM-35 series designates a family of active power factor corrected AC/DC isolated modules designed to be compatible with the latest airborne input bus with single phase 115VAC/400Hz variable frequency.

This module accepts a variable frequency input from 360 to 800 Hz in the range of 95 to 140Vac and an active power factor that enables a very low level of current and voltage harmonic distortion over the entire frequency excursion.

The HGMM-35 series is compliant with numerous avionics/military standards among them with :

- the latest Airbus standards ABD100 :
 - permanent input range : 108-122Vac
 - transient : 71Vac/15ms - 180Vac/100ms
 - variable frequency : 360 - 800 Hz
 - power factor : > 0.95
- the international standard DO-160D :
 - permanent input range : 100-122Vac
 - transient : up to 180Vac/100ms
- the US military standard MIL-STD-704E :
 - permanent input range : 108-118Vac
 - transient : 80Vac/10ms - 180Vac/100ms

The HGMM-35 series includes a soft start, a permanent short circuit protection and an inhibit function.

The soft-start allows current limitation and eliminates inrush current during start-up. The short circuit protection completely protects the module against short-circuits of any duration by a shut down and restores to normal when the overload is removed.

The HGMM-35 series includes a model available with dual 2 x 17 Vdc outputs serialisable/parallable 17 or 34 Vdc to optimize the use of hold-up capacitance.

The HGMM-35 series has to be used as front-end in conjunction with a capacitance for hold-up and DC/DC modules at the output.

The design has been carried out with surface mount components and is manufactured in a fully automated process to guarantee high quality. Every module is tested with a Gaia Converter automated test equipment. The modules are potted with a bi-component thermal conductive compound and packaged in a metallic case to ensure the module's integrity under high environmental conditions.

4

2- Product Selection

HGMM - 35 - - / -

Input Voltage Range	Output
W : 95-140 VAC/400 Hz	17 : 2 x 17 VDC

Options :
 /T : option for -55°C start up operating temperature
 /S : option for screening and serialization

Suffix :
 nothing : RoHS process
 -L : leaded process (available in N. America)

3- Electrical Specifications

Data are valid at +25°C, unless otherwise specified.

Parameter	Conditions	Limit or typical	Units	HGMB-35-W-17
Input				
Nominal input voltage	Full temperature range between phase and neutral	Nominal	VAC	115
Permanent input voltage range (Ui)	Full temperature range between phase and neutral	Min. - Max.	VAC	95 - 140
Transient input voltage	Full temperature range between phase and neutral	Min. - Max.	VAC/ms	71 / 15 180 / 100
Frequency range permanent	Full temperature range Ui min. to max.	Min. Max.	Hz	360 - 800
Frequency range transient	Full temperature range Ui min. to max.	Transient compliant with ABD100	Hz/s	320 / 0,3
Power Factor (PF)	Ui nominal at 400Hz	At full load At half load At quarter load	/	0.99 0.98 0.90
Total Harmonic Distorsion (THD)	Ui min. to max.	from 50% to full load from 400Hz to 800Hz	%	< 10
Individual current harmonic distorsion	Ui min. to max. from 360Hz to 800Hz	on all harmonics	/	see page 3
Start up input voltage	Full load with nominal output	Minimum	VAC	TBD
Start up time	Ui min. to max., 400Hz at full load with resistive load	Maximum	ms	60
Inrush current	Ui nominal, 400Hz	Nominal	A	1
Input current in short circuit mode (Average)	Ui nominal, 400Hz Short-circuit	Maximum	mA	TBD
No load input current	Ui nominal, 400Hz No load	Maximum	mA	45
Current in inhibit mode	Ui nominal, 400Hz Inhibit	Maximum	mA	30
Output				
Output voltage	Full temperature range Ui min. to max., Full load	Dual output Nominal Isolated	VDC	2 x 17 VDC
Set point accuracy	Ambient temperature : +25°C Ui nominal, 75% load, 400Hz		%	+/-4
Output power	Full temperature range Ui min. to max.	Maximum	W	35
Output current	Full temperature range Ui min. to max.	Maximum	A	1,05
Ripple output voltage	Ui nominal, 400Hz Full load with 4.400µF output capacitor per output BW=20MHz	Maximum	mVpp	200
Line regulation	Ui min. to max., 400Hz Full load	Maximum	%	+/-1
Load regulation	Ui nominal, 400Hz 25% to full load	Maximum	%	+/-4
Efficiency	Ui nominal, 400Hz Full load	Typical	%	84
Maximum admissible capacitive load	Ui nominal, 400Hz Full load	Maximum per output	µF	14.000

3- Electrical Characteristics (continued)

3-1 Power Factor (PF) Characteristics

The Power Factor (PF) is the ratio of the «real» power to the apparent power.

The apparent power is the product of the rms volts measured with one meter and the rms amps measured with another meter (value in VA).

The «real» power is the time average of the instant product of voltage and current (value in Watts).

The «real» power cannot be measured directly with 2 meters as it has to integrate the phase shift between voltage and current. This phase shift between voltage and current reduces the effective power delivered.

The Power Factor (PF) is a measure of the effectiveness with which an AC load can extract the usable power from an AC source.

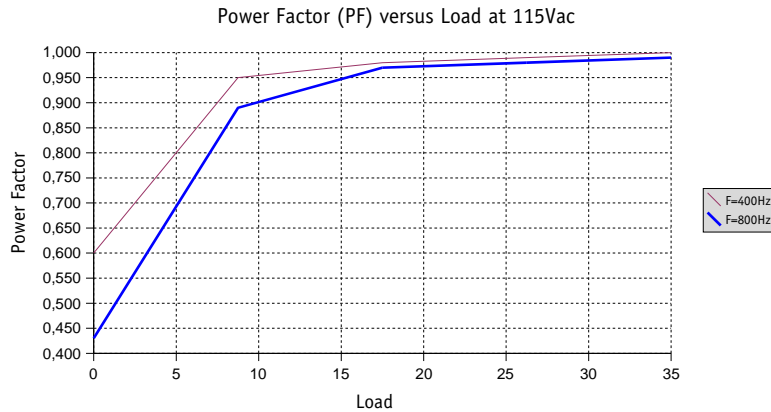

3-2 Total Harmonic Distorsion Factor (THD) Characteristics

The Total Harmonic Distorsion (THD) is the ratio between the total energy contained in all row harmonic (except fundamental harmonic) by the fundamental harmonic wave.

The following curves represent the HGMM-35 Total Harmonic Distorsion Factor at frequency of 400 Hz and at frequency of 800 Hz.

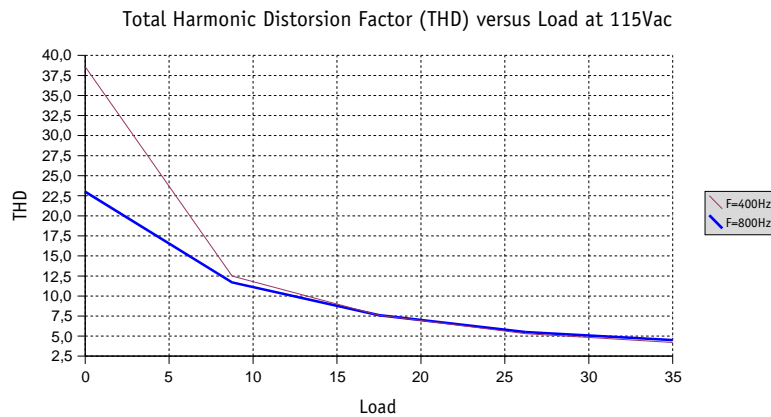

3-3 Individual Current Harmonic Distorsion Characteristics

The individual current harmonic distorsion requirement is a very specific requirement defining for each harmonic row, the maximum admissible current in all functioning conditions.

This requirement induced the Total Harmonic Distorsion Factor (THD) defined above.

These requirements are defined by the aircraft manufacturers in proprietary (and confidential) standards.

GAIA Converter HGMM series comply with individual current harmonic distorsion requirements of :

- AIRBUS ABD100 section 1.8 with specific limits on :
 - odd non triplen and odd triplen harmonics
 - even 2 & 4 and other even harmonics
- BOEING D6-44588 with specific limits on
 - odd non triplen and odd triplen harmonics
 - even harmonics

3- Electrical Characteristics (continued)

3-4 Anharmonic Input Current

The anharmonic input current of the HGMM-35 series is given hereafter for 400 Hz and 800 Hz at 35W power.

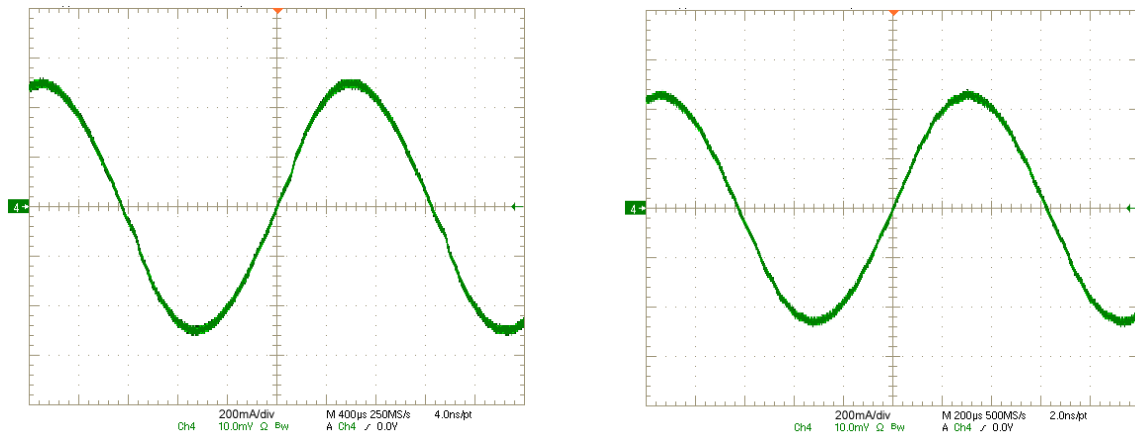

3-5 Efficiency

The efficiency of the HGMM-35 series is given hereafter for 400 Hz and 800 Hz at various load conditions.

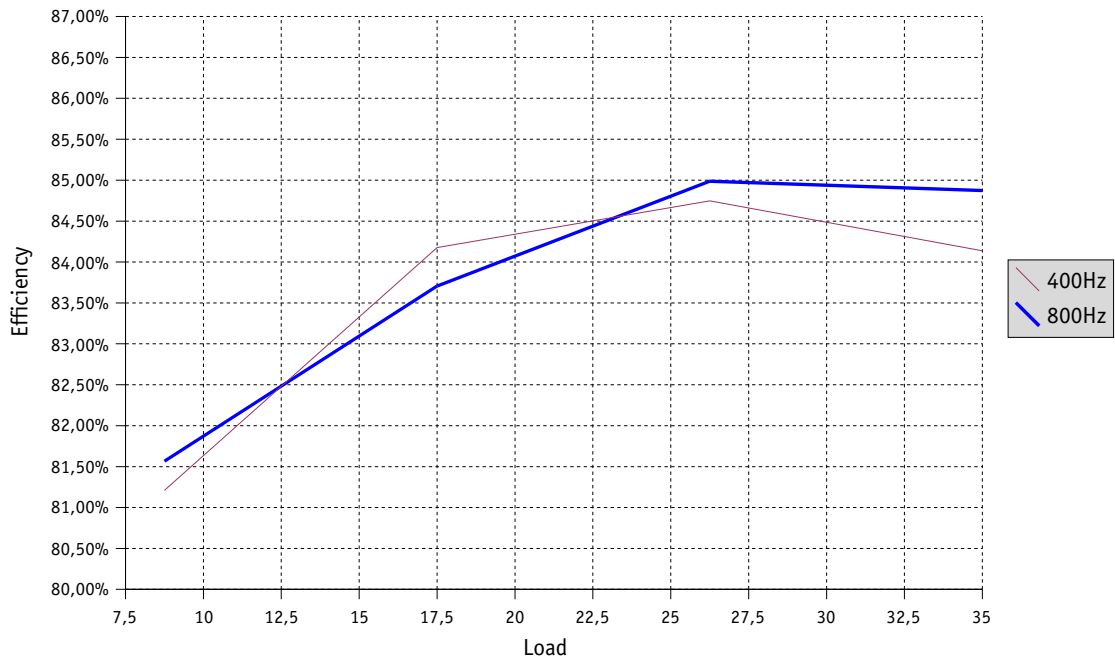

4- Switching Frequency

Parameter	Conditions	Limit or typical	Specifications
Switching frequency	Full temperature range Ui min. to max. No load to full load	Nominal, fixed	160 KHz

5- Isolation

Parameter	Conditions	Limit or typical	Specifications
Electric strength test voltage	Input to output	Minimum	1.500 VAC / 1 min
	Input to case	Minimum	1.500 VAC / 1 min
	Output to case	Minimum	1.500 VAC / 1 min
Isolation resistance	500 VDC	Minimum	100 MOhm

6- Protection Functions

Characteristics	Protection Device	Recovery	Limit or typical	Specifications
Output short circuit protection (SCP)	Hiccup circuitry with auto-recovery	Automatic recovery	Permanent	See section 11
Output overvoltage protection (OVP)	Zener clamp	/	Maximum	20 VDC

7- Reliability Data

Characteristics	Conditions	Temperature	Specifications
Mean Time Between Failure (MTBF) According to MIL-HDBK-217F	Ground fixed (Gf)	Case at 40°C Case at 85°C	730.000 Hrs 230.000 Hrs
	Airborne, Inhabited, Cargo (AIC)	Case at 40°C Case at 85°C	415.000 Hrs 145.000 Hrs
Mean Time Between Failure (MTBF) According to IEC-62380-TR	Avionics Military Cargo	/	Consult factory

8- Electromagnetic Interference

Electromagnetic interference requirements according to D0-160D or MIL-STD-461D/E can be easily achieved as indicated in the following table with the use of an additional external filter as described hereafter.

Standards	D0-160D	MIL-STD-461E	Compliance
Conducted emission (CE) : Low frequency High frequency	Section 21	CE 101 CE 102	compliant module stand alone compliant with additional filter
Conducted susceptibility (CS) : low frequency High frequency	Section 20	CS 101 CS114	compliant with additional filter compliant with additional filter
Radiated emission (RE) : Magnetic field Electrical field	Section 21	RE 101 RE 102	compliant module stand alone compliant module stand alone
Radiated susceptibility (RS) : Magnetic field Electrical field	Section 20	RS 101 RS 013	compliant module stand alone compliant module stand alone

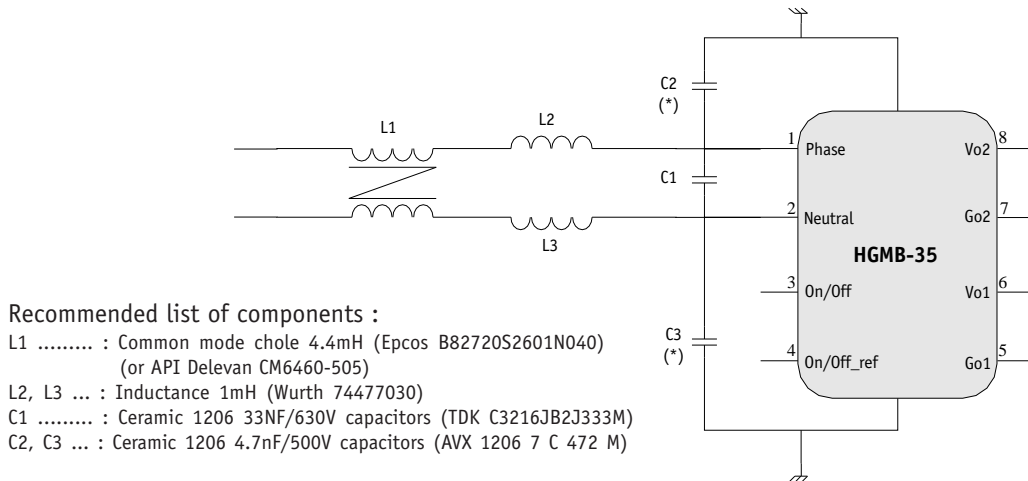
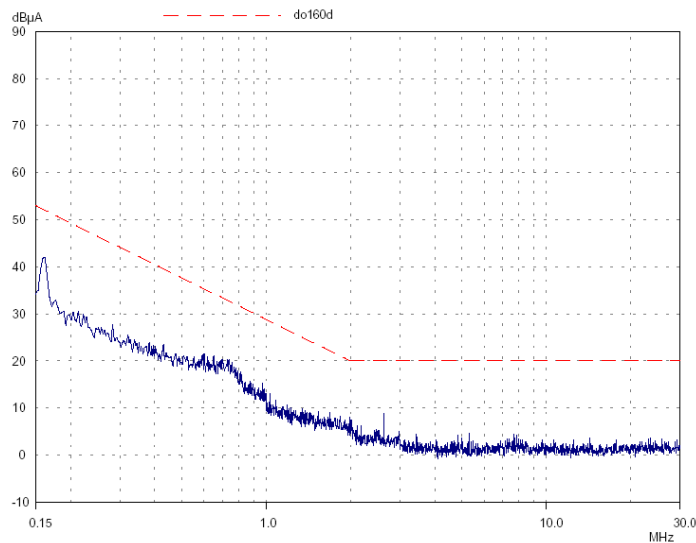

Fig : D0-160D Conducted Noise Emission



9- Thermal Characteristics

Characteristics	Conditions	Limit or typical	Performances
Operating ambient temperature range	Ambient temperature *	Minimum Maximum	- 40°C + 85°C
Operating case temperature range	Case temperature	Minimum Maximum	- 40°C + 105°C
Storage temperature range	Non functioning	Minimum Maximum	- 55°C + 125°C
Thermal resistance	Rth case to ambient in free air natural convection	Typical	6°C/W

Note * : The upper temperature range depends on configuration, the user must assure a max. case temperature of + 105°C.

The HGMM-35 series operating **case** temperature must not exceed 105°C. The maximum **ambient** temperature admissible for the converter corresponding to the maximum operating case temperature of 105°C depends on the ambient airflow, the mounting/orientation, the cooling features and the power dissipated.

To calculate a maximum admissible ambient temperature the following method can be used. Knowing the maximum case temperature $T_{case} = 105^{\circ}\text{C}$ of the module, the power used P_{out} and the efficiency η :

- determine the power dissipated by the module P_{diss} that should be evacuated :

$$P_{diss} = P_{out}(1/\eta - 1)$$

- determine the maximum ambient temperature :

$$T_a = 105^{\circ}\text{C} - R_{th} \times P_{diss}$$

where **Rth** is the thermal resistance from the case to ambient.

The previous thermal calculation shows two areas of operation :

- a normal operation area in a free natural ambient convection (grey area in this following graph),
- an area with cooling features (air flow or heatsink) ensuring a maximum case temperature below the maximum operating case temperature of 105°C (white area in the following graph).

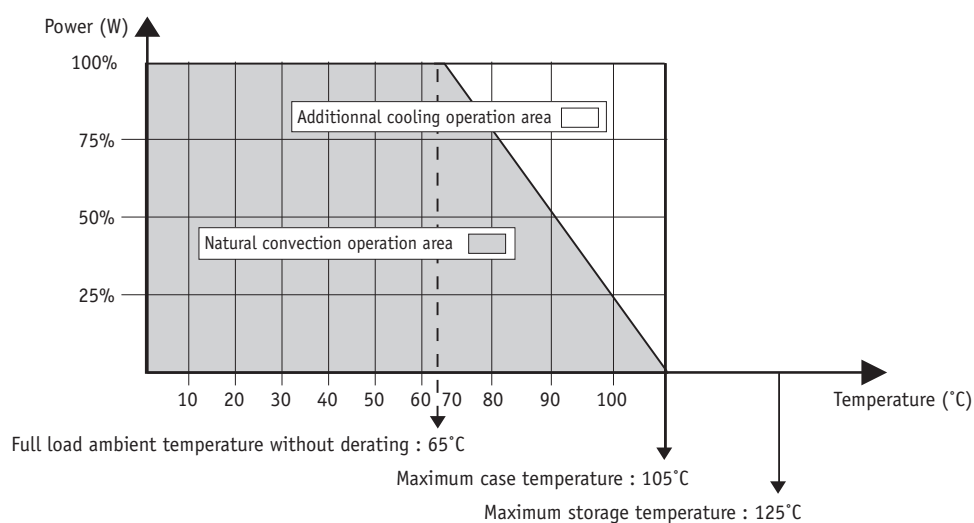

10- Environmental Qualifications

The modules have been subjected to the following environmental qualifications.

Characteristics	Conditions	Severity	Test procedure
Climatic Qualifications			
Life at high temperature	Duration Temperature / status of unit	Test D : 1.000 Hrs @ 105°C case, unit operating @ 125°C ambient, unit not operating	MIL-STD-202G Method 108A
Altitude	Altitude level C Duration Climb up Stabilization Status of unit	40.000 ft@-55°C 30 min. 1.000 ft/min to 70.000 f@-55°C, 30 min. unit operating	MIL-STD-810E Method 500.3
Humidity cyclic	Number of cycle Cycle duration Relative humidity variation Temperature variation Status of unit	10 Cycle I : 24 Hrs 60 % to 88 % 31°C to 41°C unit not operating	MIL-STD-810E Method 507.3
Humidity steady	Damp heat Temperature Duration Status of unit	93 % relative humidity 40°C 56 days unit not operating	MIL-STD-202G Method 103B
Salt atmosphere	Temperature Concentration NaCl Duration Status of unit	35°C 5 % 48 Hrs unit not operating	MIL-STD-810E Method 509.3
Temperature cycling	Number of cycles Temperature change Transfert time Steady state time Status of unit	200 -40°C / +85°C 40 min. 20 min. unit operating	MIL-STD-202A Method 102A
Temperature shock	Number of shocks Temperature change Transfert time Steady state time Status of unit	100 -55°C / +105°C 10 sec. 20 min. unit not operating	MIL-STD-202G Method 107G
Mechanical Qualifications			
Vibration (Sinusoidal)	Number of cycles Frequency / amplitude Frequency / acceleration Duration Status of unit	10 cycles in each axis 10 to 60 Hz / 0.7 mm 60 to 2000 Hz / 10 g 2h 30 min. per axis unit not operating	MIL-STD-810D Method 514.3
Shock (Half sinus)	Number of shocks Peak acceleration Duration Shock form Status of unit	3 shocks in each axis 100 g 6 ms 1/2 sinusoidal unit not operating	MIL-STD-810D Method 516.3
Bump (Half sinus)	Number of bumps Peak acceleration Duration Status of unit	2000 Bumps in each axis 40 g 6 ms unit not operating	MIL-STD-810D Method 516.3

11- Description of Protections

11-1 Output Short Circuit Protection (SCP)

The short circuit protection device protects the module against short circuit of any duration and restores the module to normal operation when the short circuit is removed. It operates in «hiccup» mode by testing periodically if an overload is applied (typically every 1s recovery time). The overload detection threshold is typically 200% of maximum current with a detection time lower than 5ms.

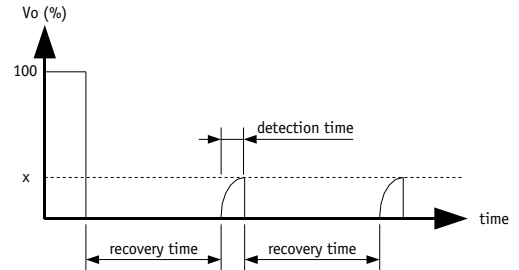

11-2 Output Overvoltage Protection (OVP)

The output overvoltage protection device protects external components against high voltage or possible overvoltages which can be supplied by the module (i.e in case of internal failure). It consists of a zener diode clamping the output voltage; under worst case conditions this zener diode will short-circuit.

The output voltage protection is not designed to withstand externally applied output overvoltages to protect the module itself.

4

12- Description of Functions

12-1 On/Off Function

The On/Off function is performed with an internal optocoupler.

It is driven through pins 3 and 4 :

- When the switch is open, the module is turned on
- When the switch is closed the module is turned off.

Parameter	Unit	Min.	Typ.	Max.	Notes, conditions
On/Off module enable current	μA	/	/	200	
On/Off module disable current	mA	2.5	/	20	
On/Off module enable delay	Vdc	/	/	/	See start-up time
On/Off module disable delay	μs	/	/	100	Vin, full load

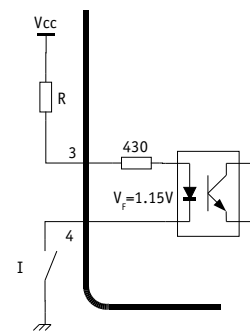

13- Application Notes

The HGMM-35 series can be connected in two ways :

- connection in parallel
- connection in series

In addition, the HGMM-35 series has to be used in conjunction with an external hold-up capacitance across the outputs to keep a good power factor and to limit the output voltage ripple. This hold-up capacitance is also used to achieve a transparency time > 50ms.

13-1 Connection of Outputs in Series to Achieve 34Vdc Output Voltage

The connection in series of both 17 Vdc outputs provides 34Vdc output voltage (at 35W power). With a connection in series, the HGMM-35 has to be used with any of GAIA Converter J inputs 16-40 Vdc to get an optimum voltage variation between 16 Vdc and 34 Vdc to minimize the size of the hold-up capacitance. Typical value of the hold-up capacitance is ranging from 2.200 μ F (minimum value to optimize output voltage ripple) up to 6.800 μ F to obtain 50 ms transparency time.

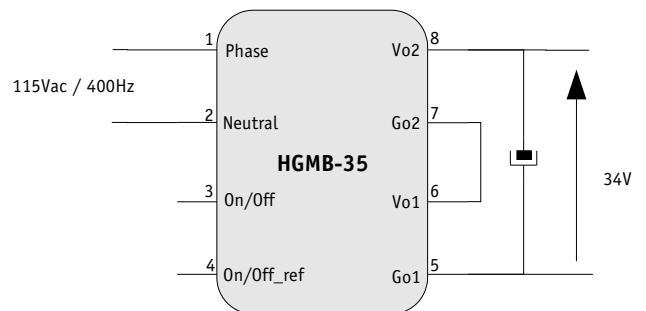

13-2 Connection of Outputs in Parallel to Achieve 17Vdc Output Voltage

The connection in parallel of both 17 Vdc outputs provides 17Vdc output voltage (at 35W power). With a connection in parallel, the HGMM-35 has to be used with any of GAIA Converter H inputs 9-36 Vdc to get an optimum voltage variation between 9 Vdc and 17 Vdc to minimize the size of the hold-up capacitance. Typical value of the hold-up capacitance is ranging from 8.800 μ F (minimum value to optimize output voltage ripple) up to 27.000 μ F to obtain 50 ms transparency time.

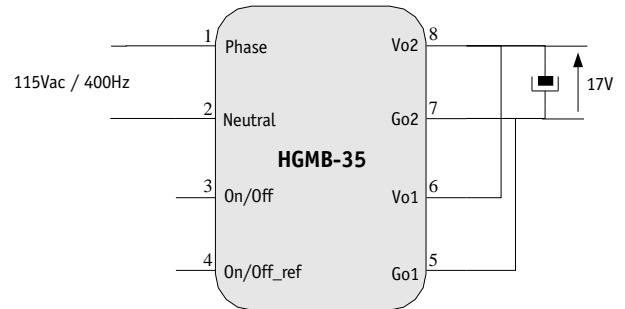

13- Application Notes (continued)

13-3 Using HGMM-35 Series for up to 70W Power Requiring Anharmonic Input Current

The HGMM-35 series can be used in 2 ways :

- single module connection to achieve 35W power
- double module connection to achieve 70W power

13-3-1 Connection to achieve 35W power

The connection in series of both 17 Vdc outputs of a single HGMM-35 allows a 35W power on a 34 Vdc intermediate bus output voltage. With a connection in series, the HGMM-35 has to be used with any of GAIA Converter J inputs (i.e 16-40 Vdc) to get an optimum voltage variation between 16 Vdc and 34 Vdc to minimize the size of the hold-up capacitance. Typical value of the hold-up capacitance is ranging from 2.200 μ F (minimum value to optimize output voltage ripple) up to 6.800 μ F to obtain 50 ms transparency time. The EMI filter is described in section 8.

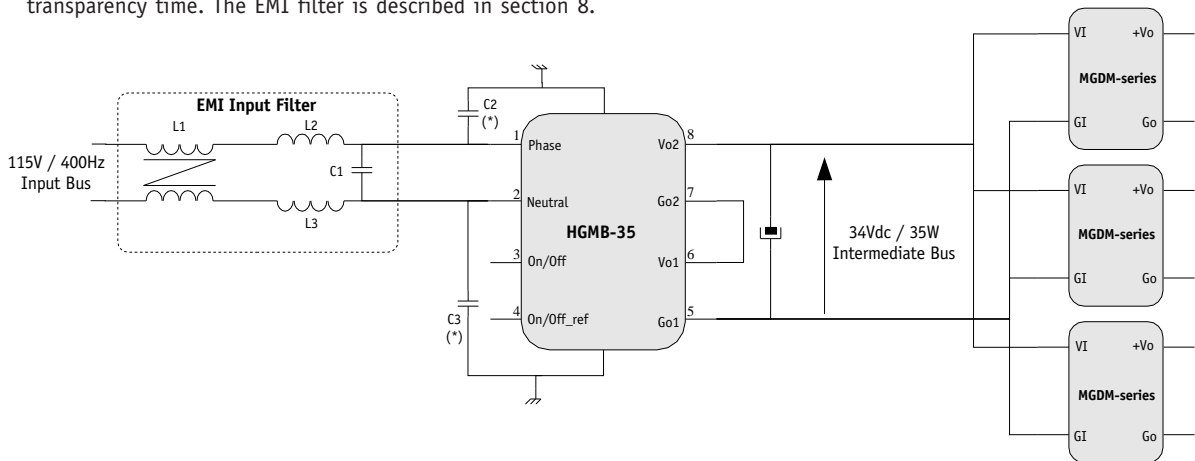

13-3-2 Connection to achieve 70W power

The connection in series of both 17 Vdc outputs of each HGMM-35 module allows a 70W power on a 34 Vdc intermediate bus output voltage. With a connection in series, the HGMM-35 has to be used with any of GAIA Converter J inputs (i.e 16-40 Vdc) to get an optimum voltage variation between 16 Vdc and 34 Vdc to minimize the size of the hold-up capacitances. Typical value of the 2 hold-up capacitances have to be determined according to section 13-2 paragraph «Connection in Parallel to achieve 17Vdc output voltage». The EMI filter structure is the same as for a single module connection (see section 8), the three inductances have to be rated twice the current value as for a single module solution, the capacitor C1 is doubled, C2 and C3 remain the same.

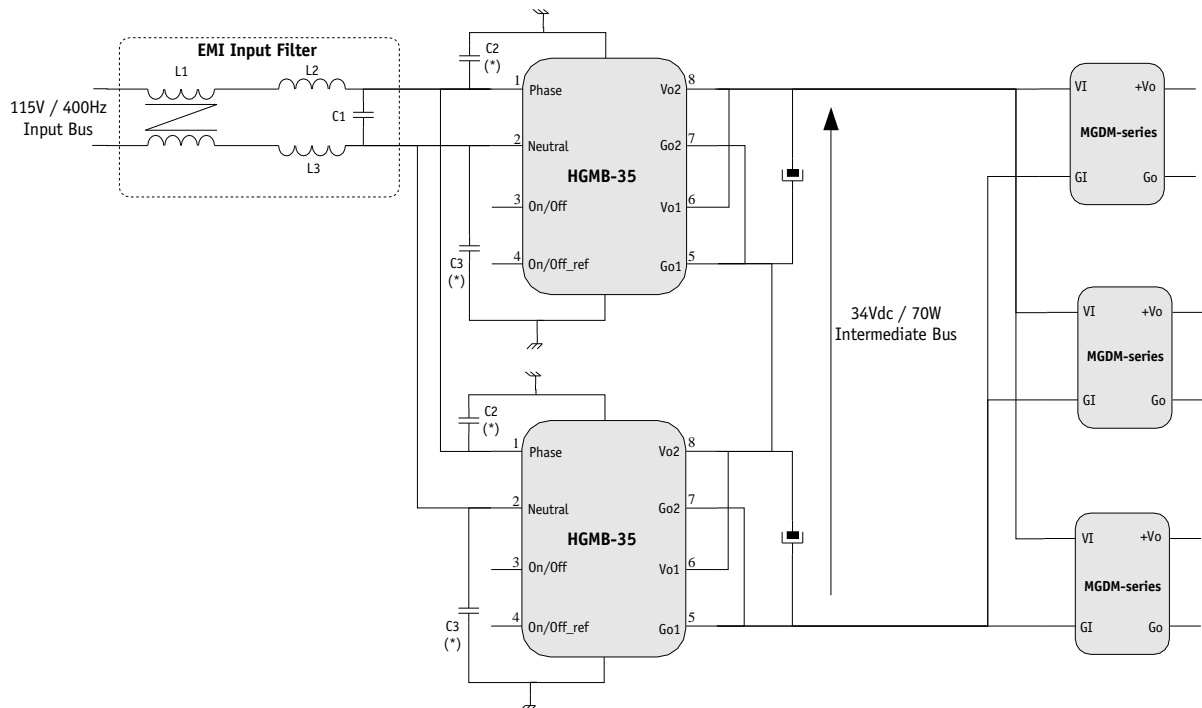

14- Dimensions

Dimension are given in mm (inches). Tolerance : +/- 0,2 mm (+/- 0.01 ") unless otherwise indicated.
Weight : 80 grams (2.80 Ozs) max.

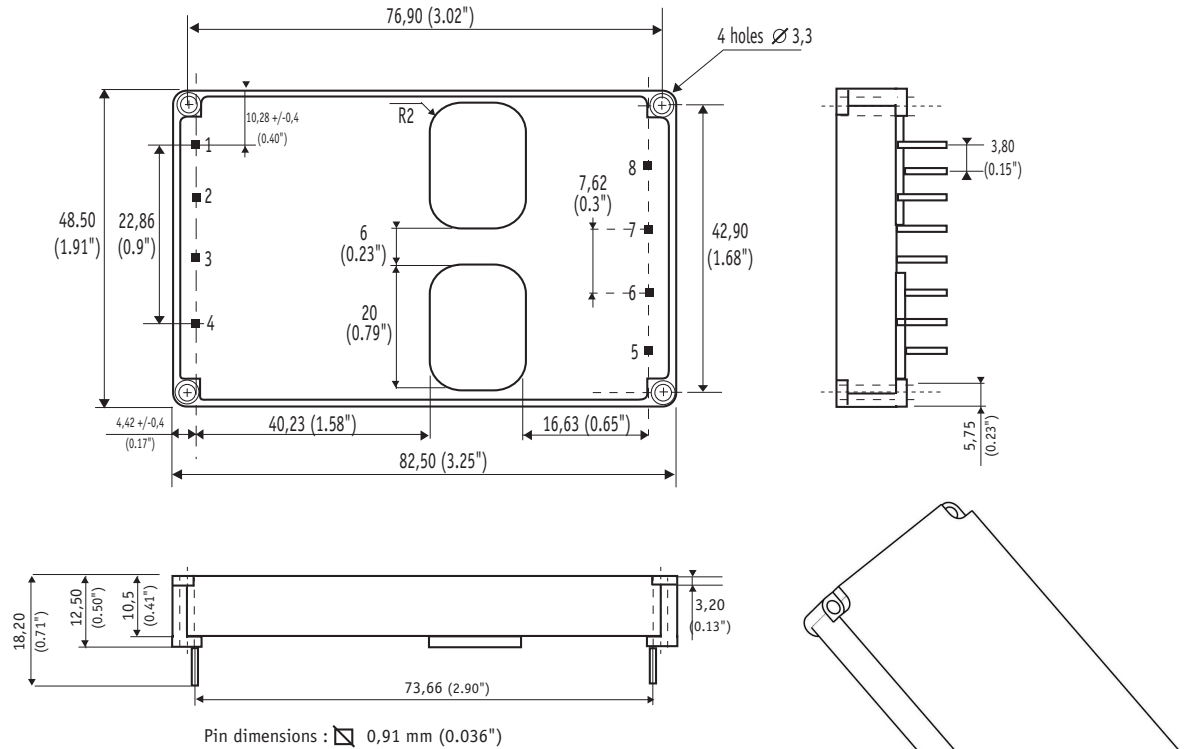

15- Materials

Case : Metallic black anodized coating.

Pins : Plated with pure matte tin over nickel underplate.

16- Product Marking

Upper face : Company logo, location of manufacturing.

Side face : Module reference : HGMMx-35-»X»-»Y».

Date code : year and week of manufacturing, suffix, /option.

17- Connections

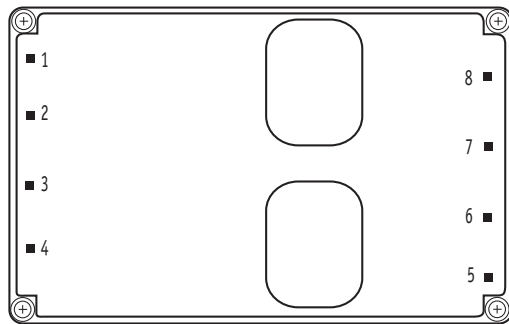

Pin	Bi-output
1	Phase
2	Neutral
3	On/Off
4	On/Off ref.
5	Common 1 (G01)
6	Output 1 (V01)
7	Common 2 (G02)
8	Output 2 (V02)



For more detailed specifications and applications information, contact :

International Headquarters

GAIA Converter - France
ZI de la Morandière
33185 LE HAILLAN - FRANCE
Tel. : + (33)-5-57-92-12-80
Fax : + (33)-5-57-92-12-89

North American Headquarters

GAIA Converter Canada, Inc
4038 Le Corbusier Blvd
LAVAL, QUEBEC - CANADA H7L 5R2
Tel. : (514)-333-3169
Fax : (514)-333-4519

Represented by :