



Wirnet Station 868

LoRaWAN™ gateway for smart IoT chain

- 868 MHz ISM band LongRange™ bidirectional communications capabilities
- Embedded, remote and open low power communication station
- Open development framework based on standard Linux OS
- WAN connectivity over GPRS/EDGE/3G or Ethernet

1. Hardware Key Features

1.1 System

CPU:

- Based on ARM 926 EJS core processor
- Up to 230 MIPS
- Real-time clock saved by battery
- Hardware watchdog
- Optimized power consumption management

Volatile memory:

- Low power DDRAM 128 MB
- 10 MB used for system firmware

Non-volatile memory

- 128 MB NAND flash (40 MB used for system firmware and auto recovery mechanism)
- 8 GB eMMC

1.2 User interfaces

Internal LEDs:

- Operational status: power, GSM signal strength level, WAN connectivity indicator

USB host interface allowing:

- Local software upgrade with simple USB key
- USB/NET local configuration/maintenance access

Internal push buttons:

- Manual station resets
- Manual test or installation procedure launch

1.3 Communication

LongRange

- Incorporate LoRa™ bidirectional communications technology (Rx: 863-873 MHz, TX: 863-873MHz)
- Sensitivity: up to -141 dBm
- Tx conducted power from 0dBm to +27dBm
- 49 LoRa™ demodulators over 9 channels
- More than 15 km range in sub-urban situation
- More than 2km range in urban situation

WWAN:

- HSDPA/UMTS (900/2100MHz): DL 7,2Mbps/UL 5,6 Mbps (HSDPA), UL/DL, 384Kbps (UMTS)
- GPRS/EDGE (900/1800): UL/DL 85.6Kbps (GPRS), UL/DL 236.8 Kbps (EDGE)
- IMEI inside
- Internal antenna

Ethernet:

- PowerOverEthernet IEEE 802.3af alternative compliant

1.4 Positioning & Timing

GPS:

- Integrated GNSS high sensitivity GPS module
- NMEA 2.0 compliant
- Internal antenna

1.5 Sensors

- Embedded temperature sensor
- Door opening detection system

1.6 Power

- PowerOverEthernet supply: 48V class 0 (Max: 15Watts, nominal: 3 Watts (LoRa™ Rx mode with GSM network attachment)
- DC power supply (ex: solar panel use): 11 to 30 Volts
- Power control: ignition detection, software off switching
- Back up battery (up to about 1 minute allowing safe power down)

1.7 Mechanical

Polycarbonate enclosure

Dimension: 315 x 170 x 215 (including mounting kit) - Weight: about 2 kg (including mounting kit)



1.8 Mounting

The provided mounting kit allow three different mounting options:

- Wall mounting by screwing
- Pole mounting by U-bolt (max diameter: 60mm)
- Metallic strapping mounting (tube, pipe, flue...)

The provided mounting kit can be split to install the antenna apart

1.9 Environmental

- Full operating range: -20° to +60°
- Humidity: 95% non-condensing (protective vent)
- MTBF: 20 years (according to MIL-HDBK-217F) – non-contractual
- Ingress protection: IP67
- Impact resistance: IK08
- UV resistance: UL508
- Flammability rating: UL94-V0

1.10 Certification

- Radio Directive 2014/53/EU
- Low Voltage Directive 2014/35/EU
- Electromagnetic Compatibility Directive 2014/30/EU
- The limitation of exposure of the public to electromagnetic fields specified in the Council Recommendation 1999/519/EC
- WPC (India) : ETA-610/2017-RLO(SR)

1.11 Hardware block diagram

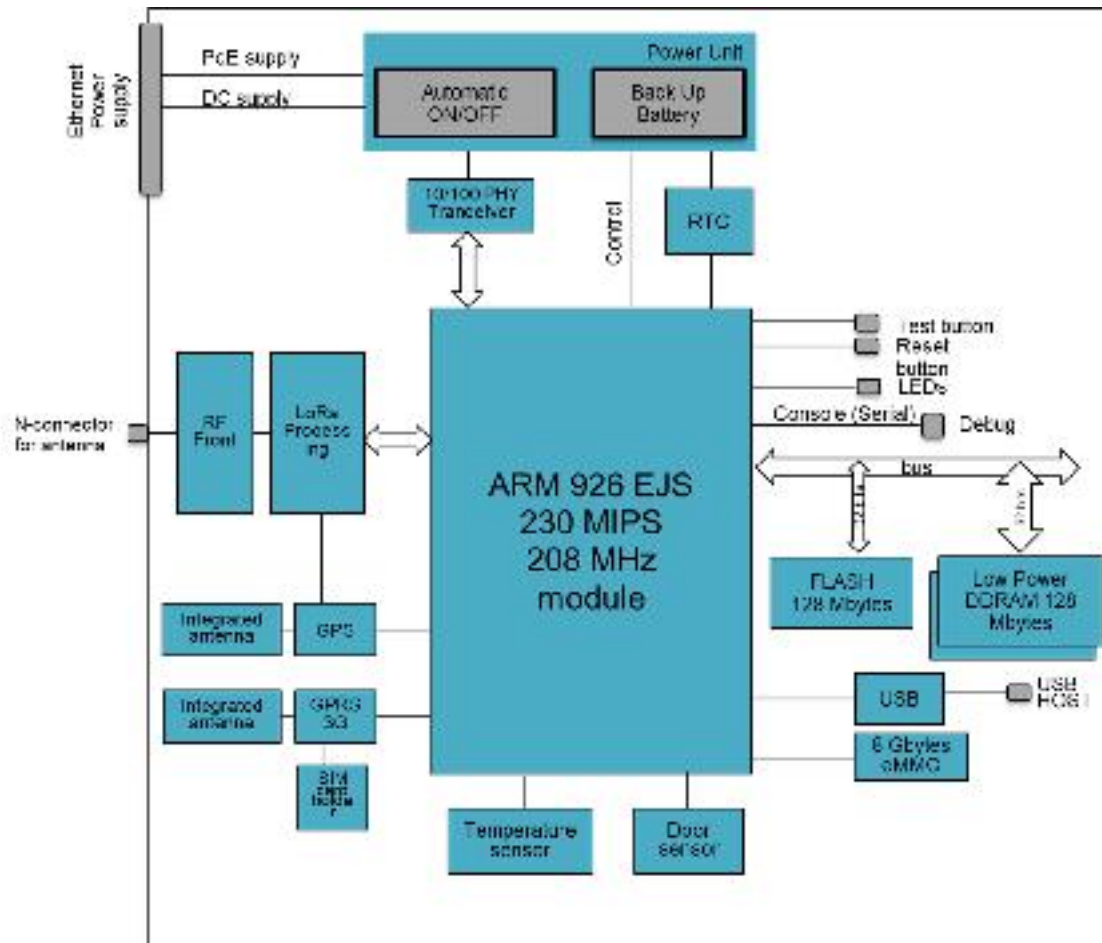

2. Software key features

2.1 Operating system

- Standard long-term support Linux version 3.10
- File system UBIFS (NAND) and EXT4 (eMMC)
- Support Of all GNU/Linux tools (cross-compiled for ARM)
- POSIX1 file system
- TCP/IP BSD4.4 socket on network bearer

2.2 Software packages included (non-exhaustive)

- Python
- SQLite
- Optional: JAVA Oracle Ojec VM (J2M2 compliant based on CDC 1.1.2 profile)

Networking:

- DHCP client and server
- FTP server
- SSH server
- NFS client
- Firewalling (iptables) and IP routing (layer 3)
- HTTP server
- TFTP server
- L2TP tunneling

2.3 KERLINK M2M services interfaces

- Simple and reduced interface using XML format over TCP/IP socket providing value added services based on action programming
- Mobile SMS management
- System alarm (memory and CPU usage, hardware failure)
- Internal statistic delivery
- Automatic or manual bearer selection
- Power control management
- Optional
- Wansy ready to remote supervision, maintenance and HQ data transfer.

2.4 Software development tools

- C/C++ Linux cross compilation toolchain based on GNU tools (GCC 4.9.3, Glibc 2.23)
- User manual and KERLINK M2M services description
- Complete C-source code set of examples for remote and embedded application
- On-line wiki
- Optional debug probe

3. Optional accessories

Antennas: various antenna can be offered to adapt to environment (omnidirectional, directional, high gain...)

4. In option: Wanesy Ready

Wanesy is a M2M platform provided by KERLINK to:

- Interconnect devices with customer ERP
- Supervise remote device (status, alarm, log...)
- maintain (remote maintenance, update and control)

The logo for kerlink features the word "kerlink" in a bold, lowercase, sans-serif font. A small icon of a globe with a signal tower is positioned above the letter "i". Below the main text, the tagline "communication is everything" is written in a smaller, lowercase, sans-serif font.

1 Rue Jacqueline Auriol
35235 THORIGNE FOUILLARD

+33 2 99 12 29 00

www.kerlink.com

www.twitter.com/kerlink_news